

SIEMENS



Operating Instructions

SINAMICS

SINAMICS IOP-2

Intelligent Operator Panel 2
Intelligent commission/configuration tool

Edition

03/2019

www.siemens.com/drives

SIEMENS

SINAMICS

Intelligent Operating Panel 2 (IOP-2)

Operating Instructions



<u>Changes in this manual</u>	1
<u>Fundamental safety instructions</u>	2
<u>Safety notes</u>	3
<u>Overview</u>	4
<u>Installation</u>	5
<u>Setup Menu</u>	6
<u>Control menu</u>	7
<u>Menu</u>	8
<u>Options</u>	9
<u>Technical data</u>	10

Edition 03/2019, Firmware IOP-2 V2.3 SP1

Legal information

Warning notice system

This manual contains notices you have to observe in order to ensure your personal safety, as well as to prevent damage to property. The notices referring to your personal safety are highlighted in the manual by a safety alert symbol, notices referring only to property damage have no safety alert symbol. These notices shown below are graded according to the degree of danger.

 DANGER
indicates that death or severe personal injury will result if proper precautions are not taken.
 WARNING
indicates that death or severe personal injury may result if proper precautions are not taken.
 CAUTION
indicates that minor personal injury can result if proper precautions are not taken.
NOTICE
indicates that property damage can result if proper precautions are not taken.

If more than one degree of danger is present, the warning notice representing the highest degree of danger will be used. A notice warning of injury to persons with a safety alert symbol may also include a warning relating to property damage.

Qualified Personnel

The product/system described in this documentation may be operated only by **personnel qualified** for the specific task in accordance with the relevant documentation, in particular its warning notices and safety instructions. Qualified personnel are those who, based on their training and experience, are capable of identifying risks and avoiding potential hazards when working with these products/systems.

Proper use of Siemens products

Note the following:

 WARNING
Siemens products may only be used for the applications described in the catalog and in the relevant technical documentation. If products and components from other manufacturers are used, these must be recommended or approved by Siemens. Proper transport, storage, installation, assembly, commissioning, operation and maintenance are required to ensure that the products operate safely and without any problems. The permissible ambient conditions must be complied with. The information in the relevant documentation must be observed.

Trademarks

All names identified by ® are registered trademarks of Siemens AG. The remaining trademarks in this publication may be trademarks whose use by third parties for their own purposes could violate the rights of the owner.

Disclaimer of Liability

We have reviewed the contents of this publication to ensure consistency with the hardware and software described. Since variance cannot be precluded entirely, we cannot guarantee full consistency. However, the information in this publication is reviewed regularly and any necessary corrections are included in subsequent editions.

Table of contents

1	Changes in this manual	5
2	Fundamental safety instructions	7
2.1	General safety instructions	7
2.2	Warranty and liability for application examples	7
2.3	Industrial security	8
3	Safety notes	11
3.1	Warnings and cautions	11
4	Overview	13
4.1	Introduction	13
4.2	Layout and functions.....	14
4.3	Screen icons	17
4.4	Menu structure	19
5	Installation	21
5.1	Fitting the IOP-2.....	21
5.2	Initial set-up.....	22
5.3	User definable labels on status screen.....	26
5.4	Upgrading the IOP-2 firmware	27
6	Setup Menu	29
6.1	Example Setups.....	30
6.1.1	Quick Startup with the IOP-2	33
6.1.2	Advanced Startup with the IOP-2	37
7	Control menu	41
7.1	Setpoint.....	42
7.2	Reverse.....	42
7.3	Jog	43
7.4	Custom Hand mode	43
7.5	Startup in Hand mode	45
7.6	HAND/AUTO disable	46
8	Menu	49
8.1	Menu overview.....	49
8.2	Diagnostics	49
8.3	Parameters	53

8.4	Up/Download.....	56
8.5	Support.....	57
8.6	Customer parameter sets	59
8.7	Extras Menu	64
9	Options	73
9.1	Door mounting kit	73
9.2	Hand-held device	75
10	Technical data	79
10.1	Technical specifications	79
	Index	81

Changes in this manual

Changes to this manual - Edition 03/2019

Listed below are the specific changes that have been incorporated in this new version of the IOP-2.

Changes

- General redesign of the IOP-2 interfaces.
- Application Setup has been added to the Advanced Startup in the Setup menu.



Advanced Startup with the IOP-2 (Page 37)

Fundamental safety instructions

2.1 General safety instructions

 WARNING
Danger to life if the safety instructions and residual risks are not observed
If the safety instructions and residual risks in the associated hardware documentation are not observed, accidents involving severe injuries or death can occur.
<ul style="list-style-type: none">• Observe the safety instructions given in the hardware documentation.• Consider the residual risks for the risk evaluation.

 WARNING
Malfunctions of the machine as a result of incorrect or changed parameter settings
As a result of incorrect or changed parameterization, machines can malfunction, which in turn can lead to injuries or death.
<ul style="list-style-type: none">• Protect the parameterization against unauthorized access.• Handle possible malfunctions by taking suitable measures, e.g. emergency stop or emergency off.

2.2 Warranty and liability for application examples

Application examples are not binding and do not claim to be complete regarding configuration, equipment or any eventuality which may arise. Application examples do not represent specific customer solutions, but are only intended to provide support for typical tasks.

As the user you yourself are responsible for ensuring that the products described are operated correctly. Application examples do not relieve you of your responsibility for safe handling when using, installing, operating and maintaining the equipment.

2.3 Industrial security

Note

Industrial security

Siemens provides products and solutions with industrial security functions that support the secure operation of plants, systems, machines and networks.

In order to protect plants, systems, machines and networks against cyber threats, it is necessary to implement – and continuously maintain – a holistic, state-of-the-art industrial security concept. Products and solutions from Siemens constitute one element of such a concept.

Customers are responsible for preventing unauthorized access to their plants, systems, machines and networks. Such systems, machines and components should only be connected to an enterprise network or the Internet if and to the extent such a connection is necessary and only when appropriate security measures (e.g. using firewalls and/or network segmentation) are in place.

For additional information on industrial security measures that can be implemented, please visit:

Industrial security (<https://www.siemens.com/industrialsecurity>)

Siemens' products and solutions undergo continuous development to make them more secure. Siemens strongly recommends that product updates are applied as soon as they become available, and that only the latest product versions are used. Use of product versions that are no longer supported, and failure to apply the latest updates may increase customer's exposure to cyber threats.

To stay informed about product updates, subscribe to the Siemens Industrial Security RSS Feed at:

Industrial security (<https://www.siemens.com/industrialsecurity>)

Further information is provided on the Internet:

Industrial Security Configuration Manual
(<https://support.industry.siemens.com/cs/ww/en/view/108862708>)

 **WARNING**

Unsafe operating states resulting from software manipulation

Software manipulations, e.g. viruses, Trojans, or worms, can cause unsafe operating states in your system that may lead to death, serious injury, and property damage.

- Keep the software up to date.
- Incorporate the automation and drive components into a holistic, state-of-the-art industrial security concept for the installation or machine.
- Make sure that you include all installed products into the holistic industrial security concept.
- Protect files stored on exchangeable storage media from malicious software by with suitable protection measures, e.g. virus scanners.
- On completion of commissioning, check all security-related settings.
- Protect the drive against unauthorized changes by activating the "Know-how protection" converter function.

Safety notes

3.1 Warnings and cautions

Warnings and cautions

 **DANGER**

Ensuring a safe and stable state

During commissioning of the converter it is essential to ensure that the system is in a safe and stable state, as some commissioning processes have the potential to start the motor. Therefore it is important to secure any loads and ensure that should the motor start, no potentially dangerous conditions exist.

 **WARNING**

The converter will stop if the IOP-2 is removed when in Hand mode

When the IOP-2 is in Hand mode, that is, when the command source is switched to Hand and all OFF and RUN commands are given via the IOP-2 buttons.

When in the Hand mode, if the IOP-2 is removed from the converter, the converter will stop within a few seconds of the IOP-2 being removed.

Before removing the IOP-2, ensure that the IOP-2 is placed in AUTO mode and receiving its command source from the PLC.

 **WARNING**

Risk of death due to software manipulation when using exchangeable storage media

Storing files onto exchangeable storage media amounts to an increased risk of infection of the commissioning PCs, e.g. with viruses or malware. Incorrect parameter assignment can cause machines to malfunction, which can lead to injuries or death.

- Protect files stored on exchangeable storage media from malicious software using appropriate protection measures, e.g. virus scanners.

 **WARNING**

Risk of death due to software manipulation when using exchangeable storage media

Storing the parameterization (incl. Safety Integrated parameterization) on exchangeable storage media carries the risk that the original parameterization (with Safety Integrated) will be overwritten, for example, by the IOP-2 of another drive without Safety Integrated. Incorrect parameter assignment can cause machines to malfunction, which can lead to injuries or death.

- Ensure that only the IOP-2 that belongs to the respective converter is used.
- Ensure that only trained or authorized personnel have access to the enclosures, cabinets or electrical equipment rooms.

Note

- The IOP-2 can be fitted to and removed from the converter while power is applied.
- The IOP-2 will set the USS PZD (P2012) length to 4 when connected to the converter.

Overview

4.1 Introduction

Compatibility

The Intelligent Operator Panel 2 (IOP-2) has been designed to enhance the interface and communications capabilities of SINAMICS Inverters.

The IOP-2 connects to the Inverter through an RS232 interface. It has been designed to automatically recognize the following devices from the SINAMICS range:

- SINAMICS G120 CU230P-2
- SINAMICS G120 CU240B-2
- SINAMICS G120 CU240E-2
- SINAMICS G120 CU250S-2
- SINAMICS G120C
- SINAMICS G120D-2 CU240D-2*
- SINAMICS G120D-2 CU250D-2*
- SINAMICS ET 200pro FC-2*
- SINAMICS G110D*
- SINAMICS G110M*
- SINAMICS G120X
- SINAMICS G120XA

*Denotes Control Units that require the IOP-2 Hand-Held Kit to connect the IOP to the Control Unit.

Hand-Held Kit order number: 6SL3255-0AA00-4HA1.

Optical cable order number: 3RK1922-2BP00

For information on firmware and language upgrades, please see  Upgrading the IOP-2 firmware (Page 27).

Note

IOP functional support

- Drives with SINAMICS firmware 4.7 SP3 or above will support the new commission processes of "Quick Startup" and "Advanced Startup".
- Drives with GP firmware prior to version 3.4 are not fully supported by the IOP-2.
- The actual menu structure and functionality of the IOP-2 will be influenced by the following factors:
 - The software version and type of Control Unit to which the IOP-2 is fitted.
 - The firmware and software version of the IOP-2.
 - The selected functional group filtering of the parameters.

4.2 Layout and functions

Overview

The physical layout of the IOP-2 is shown below:

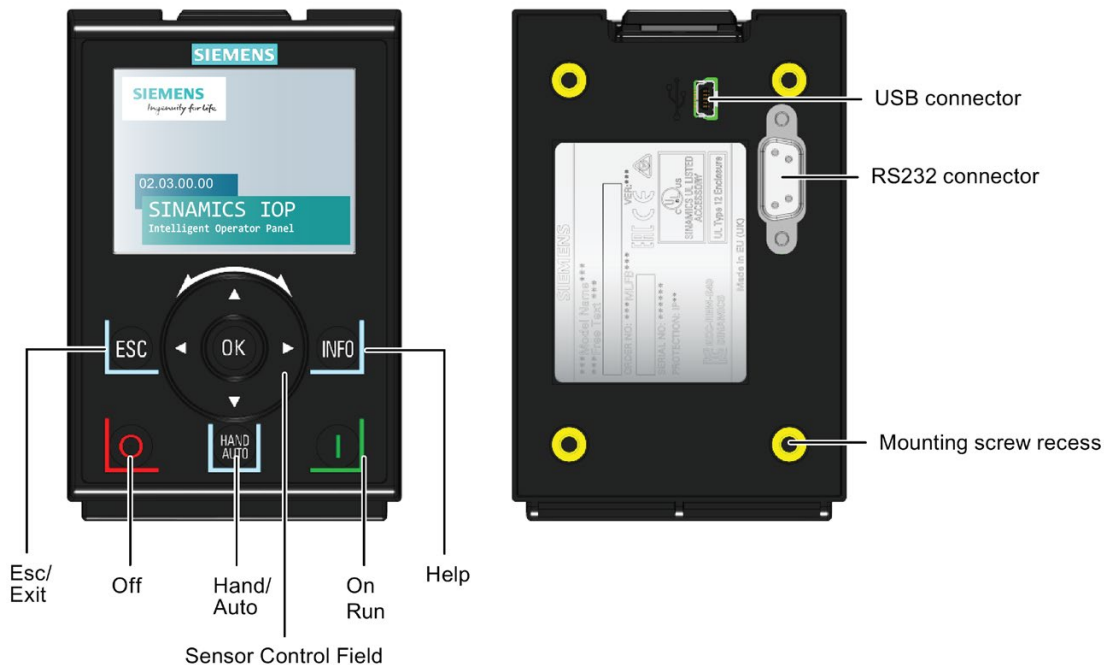







Figure 4-1 Layout of the IOP-2

The IOP-2 is operated by using a Sensor Control Field and five additional buttons. The specific functions of the Sensor Control Field and buttons are shown in the table below.

Table 4- 1 Function of the IOP-2 controls

Key	Function
	<p>The Sensor Control Field has the following functions:</p> <ul style="list-style-type: none"> • In a menu, sliding your finger around the Sensor Control Field changes the selection. • When a selection is highlighted, pressing the OK button in the centre of the Sensor Control Field confirms the selection. • When editing a parameter, sliding your finger around the Sensor Control Field changes the displayed value; clockwise increases the value and anti-clockwise decreases the displayed value. • When editing parameter or search values there is a choice to edit individual digits using the arrow keys or an entire value using the Sensor Control Field. The speed with which you slide your finger around the Sensor Control Field increases or decreases the speed of movement of the cursor. • The Sensor Control Field has integrated arrows which can be used to navigate through the menus and individual digits in the inputs fields.
	<p>The ON key has the following functions:</p> <ul style="list-style-type: none"> • In AUTO mode can be changed by pressing the HAND/AUTO key. • In HAND mode the converter is started - the converter status icon starts turning. <p>Notes:</p> <p>For Control Units with firmware versions less than 4.0: When running in AUTO mode, HAND mode cannot be selected unless the converter is stopped.</p> <p>For Control Units with firmware versions 4.0 or greater: When running in AUTO mode, HAND mode can be selected and the motor will continue to run at the last selected setpoint speed.</p> <p>When the converter is running in HAND mode, the motor stops when switched to AUTO.</p>
	<p>The OFF key has the following functions:</p> <ul style="list-style-type: none"> • If pressed for longer than 3 seconds the converter will perform an OFF2; the motor will then coast down to a standstill. Note: 2 presses of the OFF key within 3 seconds will also perform and OFF2. • If pressed for less than 3 seconds the following actions will be performed: <ul style="list-style-type: none"> – If in AUTO mode the screen will display an information screen stating that the command sources is AUTO and can be changed using the HAND/AUTO key. The converter will not be stopped. – If in HAND mode the converter will perform an OFF1; the motor will come to a standstill in the ramp-down time set in parameter P1121.
	<p>The ESC key has the following functions:</p> <ul style="list-style-type: none"> • If pressed for less than 3 seconds the IOP-2 returns to the previous screen or if a value has been edited, the new value is not saved. • If pressed longer than 3 seconds the IOP-2 returns to the status screen. <p>When using the ESC key in the parameter editing mode, no data is saved unless the OK key is pressed first.</p>

Key	Function
	<p>The INFO key has the following functions:</p> <ul style="list-style-type: none">• Displays additional information for the currently selected item.• Pressing the INFO key again will display the previous screen.• Pressing the INFO key during power-up of the IOP-2 will place the IOP-2 in DEMO mode. To exit DEMO mode, power-cycle the IOP-2.
	<p>The HAND/AUTO key switches the command source between HAND and AUTO mode.</p> <ul style="list-style-type: none">• HAND sets the command source to the IOP-2.• AUTO sets the command source to an external source, for example, fieldbus. <p>Note: When switching from the HAND mode back to the AUTO mode, the setpoint screen will change back to the standard status screen.</p>

Locking and unlocking the keypad

The keypad can only be locked once the power-up cycle has been completed. If the keys are activated before the power-up cycle is completed, the IOP-2 will enter the DEMO mode.

To lock the IOP-2 keypad press **ESC** and **INFO** simultaneously for 3 seconds or more. To unlock the keypad press **ESC** and **INFO** simultaneously for 3 seconds or more.

DEMO mode

DEMO mode allows the IOP-2 to be used for demonstration purposes without affecting the converter to which it is connected. Menus can be navigated and functions selected, but all communications with the converter are blocked to ensure that the converter does not react to any commands issued from the IOP-2.













To enter the DEMO mode it is necessary to do a long press of the ESC key or INFO key during the power-up cycle. The IOP-2 must be power cycled again to exit the DEMO mode.

4.3 Screen icons

Overview

The IOP-2 displays a number of icons at the top right-hand edge of the display to indicate various states or current conditions of the converter. These icons are explained in the table below.

Table 4- 2 Screen icons

Function	Icon	Remarks
Command source		Auto - the converter receives the command signals from the network controller
	JOG	Displayed when the JOG function is active
		Hand - the converter is under control of the IOP-2
Inverter status		
		Icon rotates when the motor is running
Fault pending		
Alarm pending		
Saving to RAM		Indicates that all recent changes to parameters have been saved in RAM only. In the event of a power failure, then all recent changes saved to RAM will be lost. To prevent loss of parameter data a RAM-to-ROM save must be performed.
PID autotuning		
Hibernation mode		
Write Protection		Parameters cannot be modified.
Know How Protection		Parameters cannot be viewed or modified.
ESM		Essential Services Mode
Battery condition		The battery status is only shown when the IOP-2 Hand-held kit is used.

Screen faults and alarm indicators

When a fault or an alarm is active on the converter the top label on the screen will turn red. The top label will remain red until the fault or warning has been acknowledged or rectified.

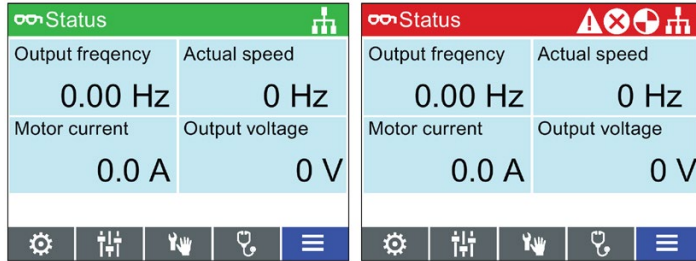

Figure 4-2 Fault and alarm notifications

Use of screen colours

A brief explanation of the use of the different colours on the screen is given below:

- Red** Error status: Indicates a fault is active and the Control Unit is in an error condition.
- White** Neutral status: The IOP-2 has no connection to the Control Unit.
- Green** Run status: The converter is running with no active faults. Active alarms will be displayed on the status bar.
- Blue** Blue denotes the selected item on the screen.

4.4 Menu structure

Overview

The Menu structure of the IOP-2 is shown in the figure below.

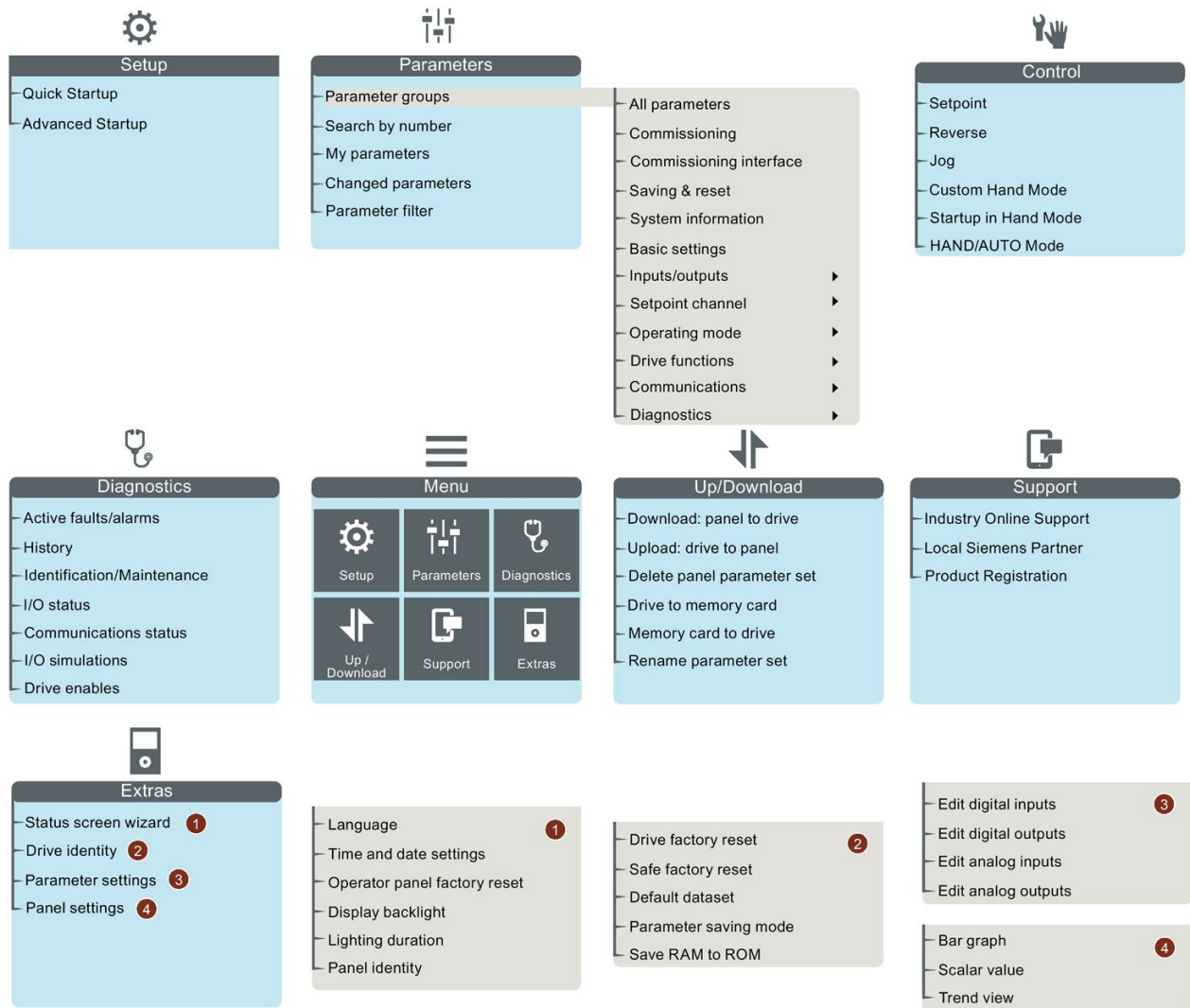

Figure 4-3 IOP-2 menu structure

Installation

5.1 Fitting the IOP-2

Fitting the IOP-2 to the Control Unit

Note

IOP-2 power supply

The IOP-2 has no internal power supply and derives its power directly from the Control Unit of the converter through the RS232 interface. The IOP-2 can also be connected to a PC and derives its power through the USB connection.

To fit the IOP-2 to the converter Control Unit the following procedure should be performed:

1. Place the bottom edge of the IOP-2 casing into the lower recess of the Control Unit housing.
2. Push the IOP-2 forward until the top fastening clicks into place on the Control Unit housing.

To use the IOP-2 with a decentralized drive, for example an ET200pro FC-2, an IOP-2 Handheld kit is required and an optical cable. The IOP-2 Handheld kit and optical cable are fitted as shown in the following figure.

The order details of both the IOP-2 Handheld kit and the optical cable are given in the  Introduction (Page 13).

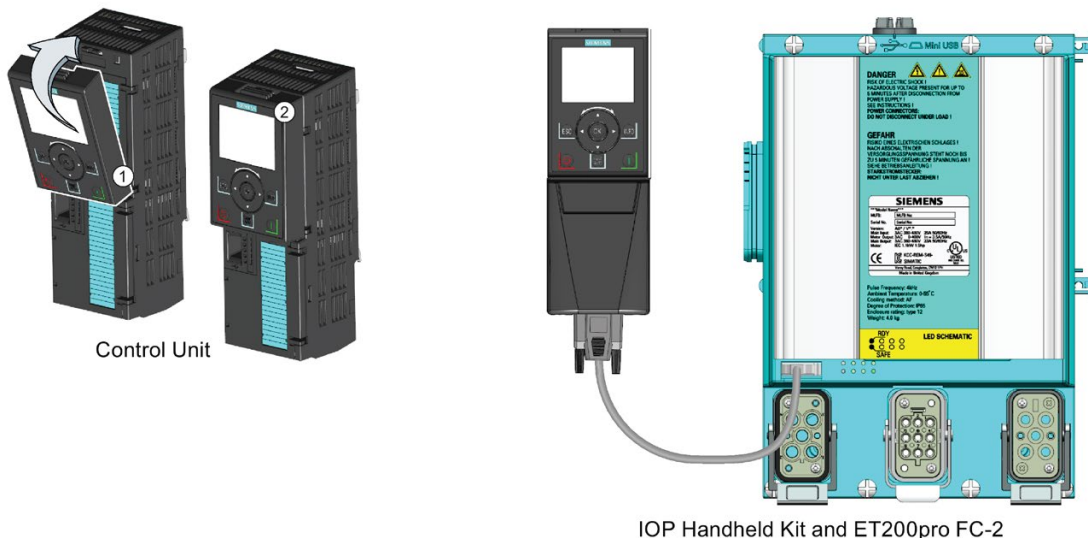

Figure 5-1 Fitting IOP-2 on CU and ET200pro FC-2

5.2 Initial set-up

Initial set-up sequence

Once the IOP-2 is fitted and powered-up it will automatically detect the type of Control Unit and Power Module to which it has been fitted. On first-time use, the IOP-2 automatically displays the option to select the default language and allow the time and date to be set (if the Control Unit to which the IOP-2 is fitted has a real-time clock). The IOP-2 will then display the choice between "Quick Startup" or Advanced Startup"; "Quick Startup" is the recommended selection. The procedure is outlined below.

Note

Saving and cloning of the IOP-2 configuration data

All changes made to an IOP-2 configuration, included all saved parameter sets, are stored in the IOP-2 file structure in the "user" folder.

To copy/clone all this data to another, or multiple IOP-2s, the procedures are shown in



Customer parameter sets (Page 59).

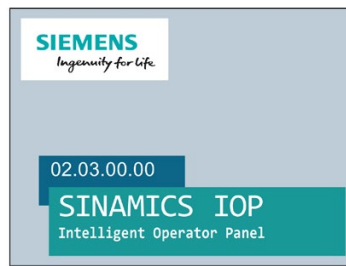

Splash screen is displayed



Select the required language

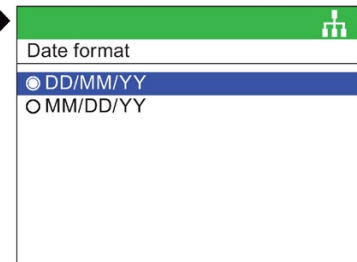

Select date format



Set correct date and time

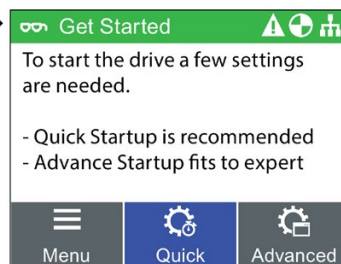

Select Quick Startup



Select "Yes, reset to factory settings"

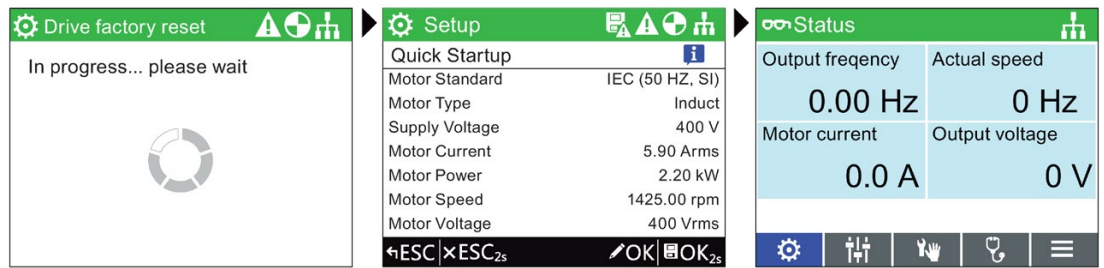

Wait until the factory reset is finished

Change or confirm settings

Status screen on completion

Note

The IOP-2 is delivered with all available languages and the Quick Startup and Advanced Startup setups. For information on Firmware upgrades, please see Upgrading the IOP-2 firmware (Page 27).

The status screen can be reconfigured to show a number of different views and types of values; these can be configured using the "Status Screen Wizard" in the "Extras" menu, see Extras Menu (Page 64).

Language selection

The IOP-2 on first start-up will display the language screen for the user to select their required language, should you wish to select your language manually, the following actions should be performed:

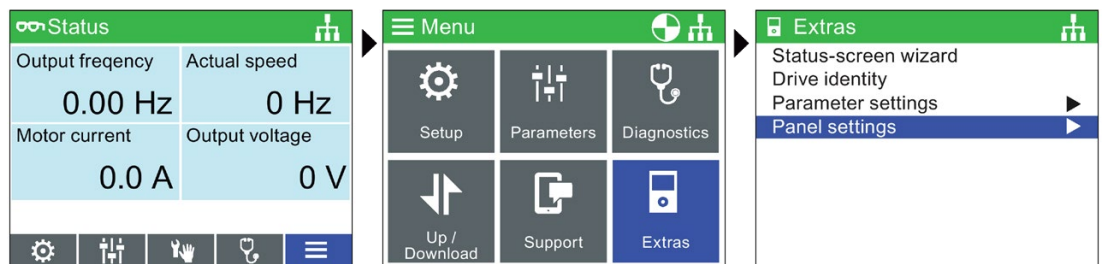

Select Menu

Select Extras

Select Panel settings



Select language

Select required language

Press and hold down ESC for Status Screen

All available languages are delivered with the IOP-2.

Setting time and date

When the IOP-2 is first fitted to a Control Unit, which has a real-time clock, it will automatically display the time and date screen. Should you wish to manually set the time on the IOP-2, the following actions should be performed:

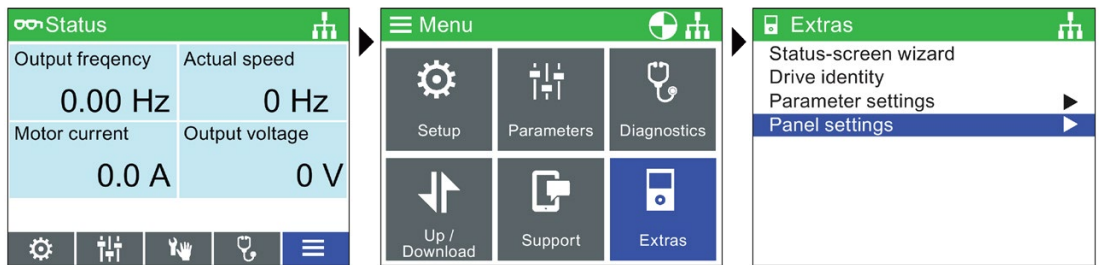

Select Menu

Select Extras

Select Panel settings

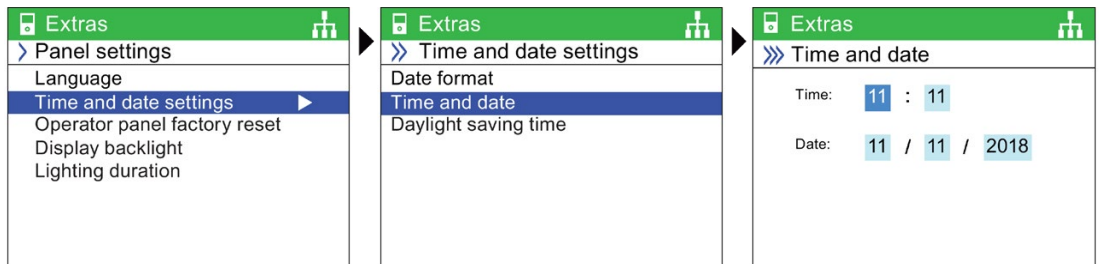

Select Time and date settings

Set the Time and date settings

Set time and date

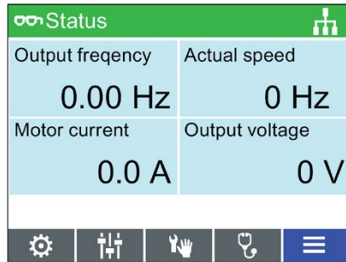

Press and hold down ESC for Status Screen

The settings for time are normally done on the Control Unit if it has a Real-time Clock (RTC). If the Inverter has an RTC the IOP-2 will take its settings from the Control Unit.

Lighting duration

To set the length of time that the display remains lit, the following actions should be performed:

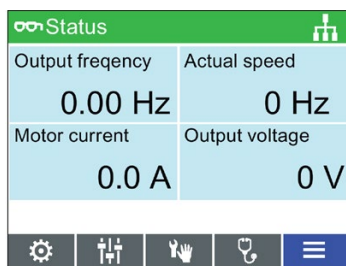

Select Menu

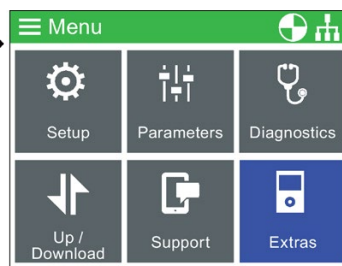

Select Extras

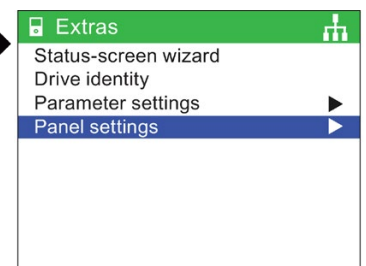

Select Panel settings

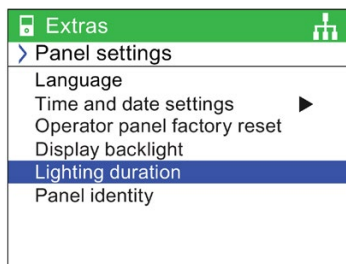

Select Lighting duration

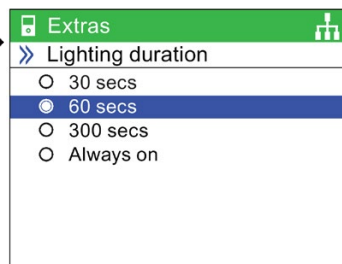

Select Lighting duration time

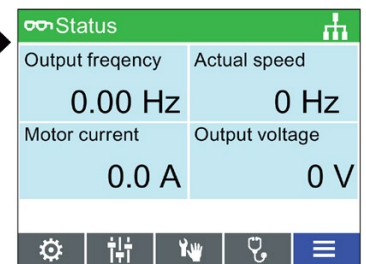

Press and hold down ESC for Status Screen

Note

Screen will flash when an active fault condition exists

When an active fault condition exists on the IOP-2, if no key has been pressed for more than one minute then the screen will start to flash on and off. The screen will dim a few seconds prior to the lighting duration time-out period. If the screen is set to never dim, that is, it has been set to "Always on" the screen will not dim.

Display backlight

To change the intensity of the backlight, the following actions should be performed:

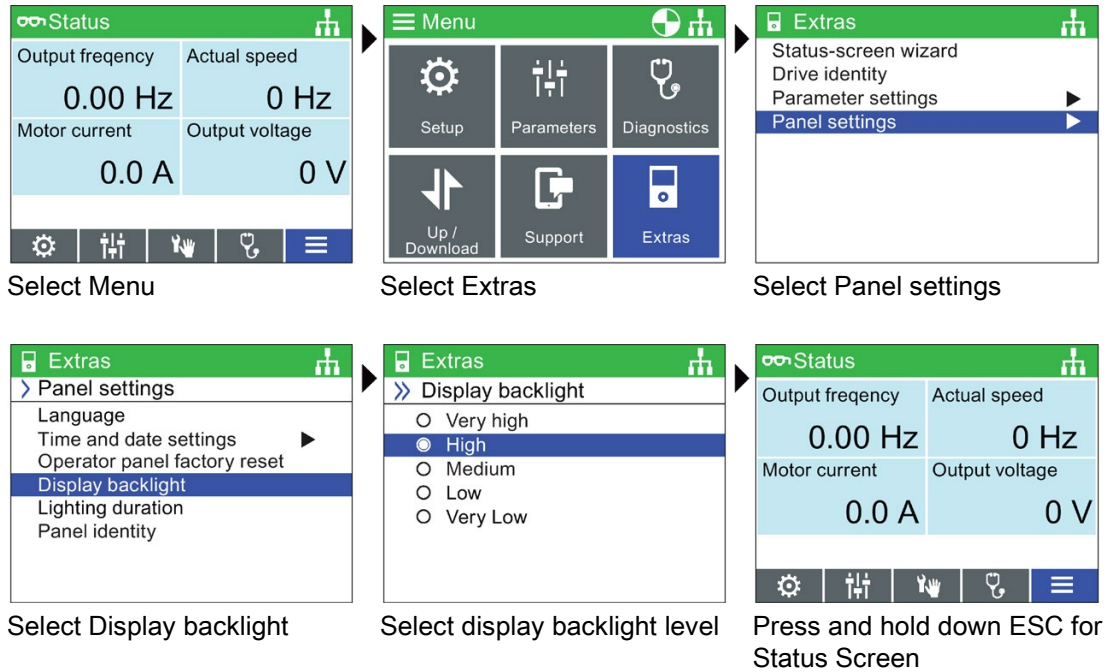

The display backlight setting will be automatically changed to the "Low" setting after 60 seconds from the last key press to extend the life of the display. When any key is pressed the backlight setting will automatically return to the user setting.

5.3 User definable labels on status screen

User definable labels

User defined labels allow the user to customize the labels that appear on the status screen of the IOP-2.

There are a maximum of four labels that can be defined and they are located on the IOP-2 in the "cps" folder. The IOP-2 must be connected to the PC via the USB connection and in "Mass Storage" mode to access the files on the IOP-2. The files are basic text files and can be opened with any basic text editor. The default label names are "default", when the labels have the "default" text, the IOP-2 will ignore the labels. There are the following restrictions when creating your own labels:

- A maximum of 20 characters for each label name.
- The characters that can be used conform to the normal windows file naming conventions.
- The number of labels are restricted depending on the type of status screen view that is selected in the "Status screen wizard". See  Extras Menu (Page 64).

The four files are named:

- BotLeft.txt
- BotRight.txt
- TopLeft.txt
- TopRight.txt

The file names relate to the area of the status where they will appear.

Simply selected the file you wish to use as a label; open it with a text editor, change the name and then save it back to the same location in the IOP-2 file system. If the file name itself is changed the IOP-2 will not recognize the label.

An example of the status screen with new label names (using all four text files) is shown in the figure below.

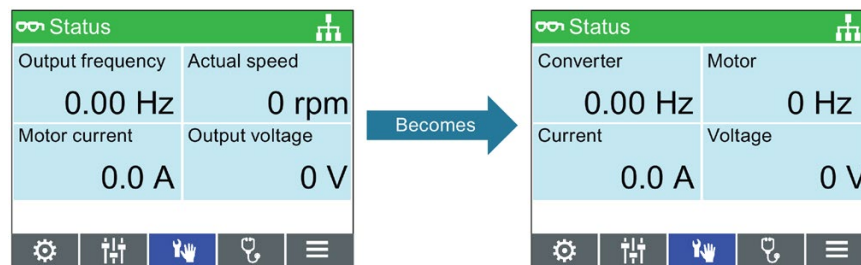

Figure 5-2 Example of defining your own labels

5.4 Upgrading the IOP-2 firmware

Upgrading the IOP-2 firmware

The IOP-2 contains firmware, which can be upgraded by the user by means of a firmware upgrade. To perform the upgrade of the IOP-2 firmware the following steps should be performed.

1. Plug the IOP-2 into a PC using the USB connection. Note: Connect the IOP-2 only to an internal USB interface. Do not use an USB interface which is connected to your PC externally (e.g. via a docking station, external USB-Hub or desktop PCs with front sockets).
2. The IOP-2 will automatically enter the "Mass Storage" mode.
3. Open the file explorer on the PC.
4. Navigate to the IOP-2 (removable media). Note: Back up data (e.g., readme, parameter records) that you will need later on the connected PC.
5. Format the IOP-2 (do not use quick formatting). Set the size of the allocation units to 2048 bytes (FAT Standard).
6. Go to the Service and Support site at the link shown below.

7. Download the zip file with the current firmware of the IOP-2 into a folder on the PC and unpack it into a separate directory.
8. Copy the downloaded files from the PC directory directly into the IOP-2 folder (the copying process takes approximate 6 minutes).
9. When the copying has been completed, wait approximate 5 seconds before disconnecting the IOP-2 from the USB port. The new firmware is now available on the IOP-2 and you can now connect the IOP-2 to a SINAMICS G inverter.
10. When you turn on the SINAMICS G inverter, the IOP-2 will automatically upgrade.

Note

English language is mandatory

The English language file is essential to the correct functioning of the IOP-2 and therefore cannot be deleted.

Only IOP-2 firmware update packages obtained through the Siemens Service and Support website at the following link should be used:



IOP-2 firmware download: IOP-2 Firmware upgrade
(<https://support.industry.siemens.com/cs/ww/en/view/109762019>)

Reading the OSS License

The IOP-2 contains open-source software (OSS). The OSS comprises open-source text and satisfies special license terms. If you wish to read the license terms, see: efs/readme_OSS.zip on the IOP-2.

Overview

The IOP-2 Setups are question-driven environment that assist the user to set-up various functions and applications of the converter.

WARNING

Motor Identification (Motor ID) function will run automatically

Using the "Standard Drive Control" or "Dynamic Drive Control" in Quick Startup, the Motor ID function, if selected, is activated at the end of the commissioning sequence.

The motor identification (motor ID) function, after the completion of the Quick Startup, upon the first startup, will start automatically after approx. 8 to 30 s and accelerate the motor to the setpoint speed.

This action must be taken into account when the Quick Startup procedure has been completed, to ensure that the first ON/RUN command when given for your application, does not produce an unpredicted or unsafe effect on personnel, equipment or premises.

WARNING

Safe and stable state of the converter

During the setup of the converter it is essential to ensure that the system is in a safe and stable state, as some setup processes have the potential to start the motor. Therefore it is important to secure any loads and ensure that should the motor start, no potentially dangerous conditions exist.

CAUTION

Default datasets

The Setups use the default Drive datasets (DDS0 and CDS0), if the default datasets are changed to the other datasets, the Setups may not function correctly.

6.1 Example Setups

Overview of Setup

The following example of how Setup work on the IOP-2 are purely for demonstration purpose only.

 **CAUTION**

Before setting up an application

Prior to using Setup, it is essential that the user's Control Unit and Power Module have been installed and wired correctly, in accordance with the requirements of the user's application. This is extremely important in the case of setting up safety-integrated applications. All inputs and outputs must be defined and configured before any setting up can take place, including the observation and adherence of all local, national and international safety regulations required for the user's application and all devices utilized by the user's application.

Quick Startup/Advanced Startup

Quick Startup

The Quick Startup procedure is all the user needs to setup the converter in quickly and easily. The Quick Startup allows the user to configure the following converter data:

- Motor Standard
- Motor Type
- Supply Voltage
- Motor Current
- Motor Power
- Motor Speed
- Motor Voltage
- Motor Frequency
- Minimum Frequency
- Maximum Frequency
- Ramp-up Time
- Ramp-down Time
- I/O Setup

The default settings of the converter will be automatically read into the IOP-2, but it is recommended that you check that these settings are correct for your converter by comparing the settings with the data from the converter and motor rating labels.

Advanced Startup

The Advanced Startup provides the user with a more comprehensive range of settings that can be configured for specific requirements and applications. The settings that are available are as follows:

- Drive Information: This displayed detailed information about the connected Control Unit and Power Module.
- Factory Reset: This allows the converter to be reset to the factory default settings.
- Hardware options: This allows the configuring of an Output Filter and a Braking Resistor.
- Control Type: This allows the selection of the control types, Standard Drive Control, Dynamics Drive Control and Expert. A brief explanation of each Control Type is given below.
- Motor Data: This allows the user to configure the Motor settings which consist of the data presented in the Quick Setup.
- Limit Settings: This gives the user the opportunity to setup the dynamics settings of the converter.
- Optimization: This allows the user to optimize the converter for technological applications and ensure that the correct motor data will be used.
- I/O Setup: This allows the user to configure the Input and Output settings of the converter. The I/O configuration is pre-assigned using macros so that no further settings are necessary.
- Fieldbus Setup: This allows the user to configure the interface settings.
- Application Setup: This allows the user to configure the application specific functions of the converter.

For more detailed information of the application classes, see the document at the link below:



Application classes (<https://support.industry.siemens.com/cs/ww/en/view/109480663>)

Control Types

Standard Drive Control

- Standard Drive Control is preset for the Power Modules PM240, PM240-2 and G120C in frame sizes FSA-C. This application class can, for example, be used for the following applications:
 - Pumps, fans and compressors with flow characteristic
 - Wet or dry beam technology, mills, mixers, kneaders, crushers, agitators
 - Horizontal conveyor technology (conveyor belts, roller conveyors, chain conveyors)
 - Basic spindles

Dynamic Drive Control

- Dynamic Drive Control is preset for the Power Modules PM240, PM240-2 and PM330 in frame sizes \geq FSD. This application class can, for example, be used for the following applications:
 - Pumps and compressors with displacement machine
 - Rotary furnaces
 - Extruders
 - Centrifuges

Expert

- Expert is fixed assigned to the Power Modules PM230, PM250 and PM260 as soon as for G120D, G110M and ET200pro FC-2. This setting corresponds to the existing Setup and will also be assigned to existing projects. It allows the flexibly setup of the converter, but requires a detailed understanding of the drive.

 **WARNING**

Motor data identification (motor ID)

When selecting motor data identification (motor ID) with subsequent ramp-up to the setpoint speed (p1900 = 11 or 12; 12 = standard setting based on SINAMICS Firmware V4.7 SP3 with "Standard Drive Control" and "Dynamic Drive Control"), the motor is, upon the first Power ON command, directly accelerated to the setpoint speed, following a short delay time caused by the motor ID (approx. 15 to 30 s). From SINAMICS Firmware V4.7 SP6 the default setting for p1900 = 2.

Note

Macro source selection

During the Quick Startup process, the user will be presented with a list of preset macros that determine the configuration of the converter. Every Control Unit Operating Instructions contain a list of the macros that are specific for that particular Control Unit and show the wiring configurations for each macro. For further information, see the relevant Operating Instructions.

Info Screens

Info Screens (Information Screens) are accessed with a press of the INFO button. There may be multiple INFO screens and these you can navigate between each screen using the arrow keys.

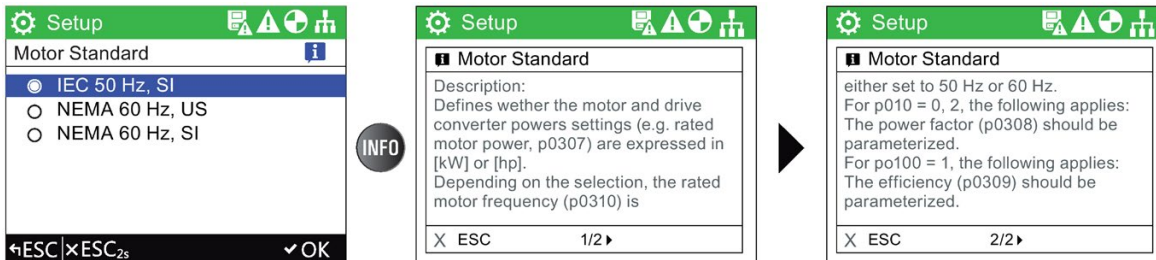

Figure 6-1 Using the INFO button

6.1.1 Quick Startup with the IOP-2

Quick Startup

NOTICE

Requirements prior to using the Quick Startup

- The user must be fully conversant with all safety instructions as detailed in the "Fundamental Safety Instructions" section of the Operating Instructions for your converter.
- The converter must be installed and checked as per the relevant instructions in the "Installation" sections of the converter Operating Instructions.
- Macro source selection: During the Quick Startup process, the user will be presented with a list of preset macros that determine the configuration of converter. Every Control Unit Operating Instructions contain a list of the macros that are specific for that particular Control Unit and show the wiring configurations for each macro. For further information, see the relevant Operating Instructions.
- The information required to be input into the Quick Startup process can be found on the motor rating label, an example of which is included in the Operating Instructions for your converter.
- If the motor is to operate with the "87 Hz characteristic"; You need to use the "Advanced Startup" process and you need to connect the motor in Delta (Δ), this is shown in the "Installation" section of the Operating Instructions for your converter.

6.1 Example Setups

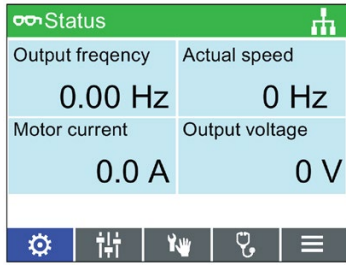

Select Setup



Select Quick Startup



Select Factory Reset (yes or no)

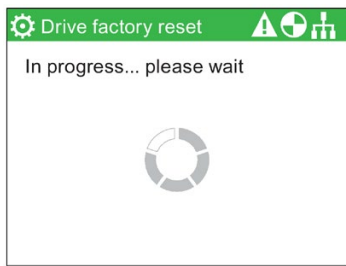

Factory Reset begins

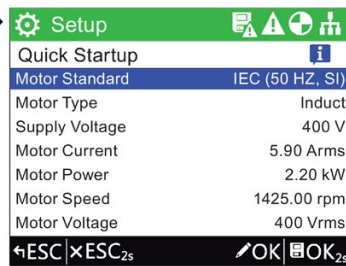

Select Motor Standard

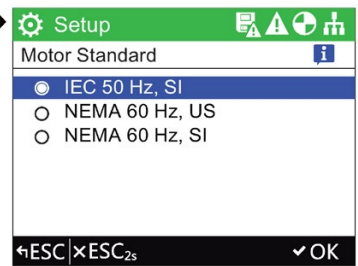

Select mains frequency and units

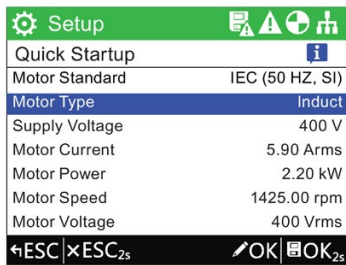

Select Motor Type

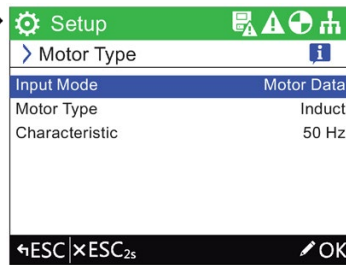

Select Input Mode

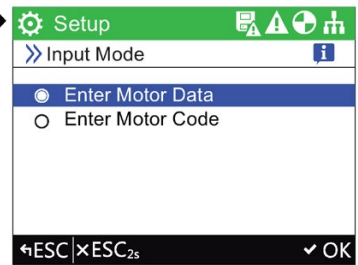

Enter Motor Data or Motor Code

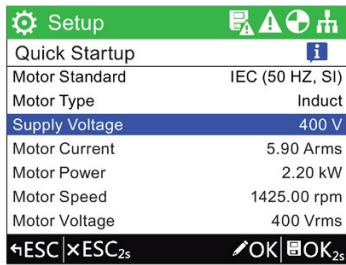

Select Supply Voltage

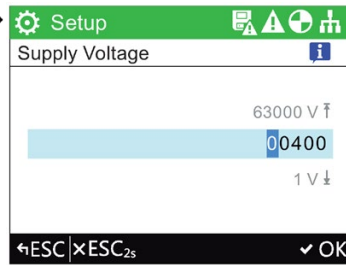

Enter Supply Voltage from rating label

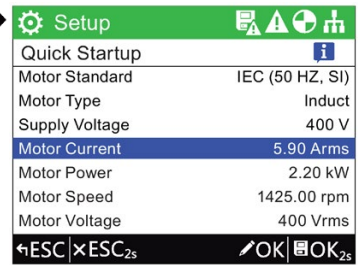

Select Motor Current

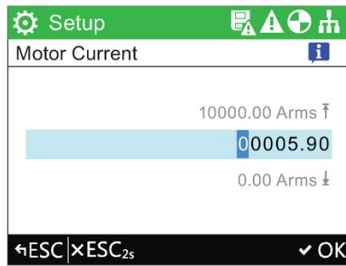

Enter Motor Current from rating label

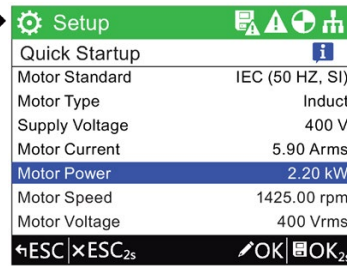

Select Motor Power

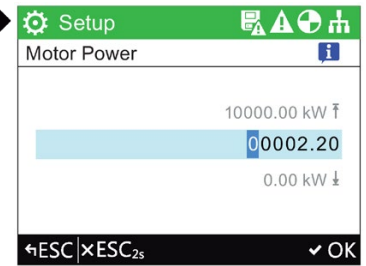

Enter Motor Power from rating label

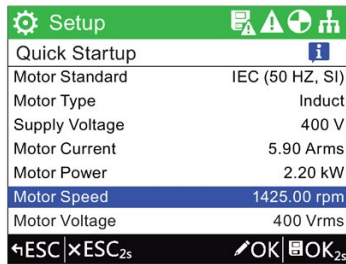

Select Motor Speed

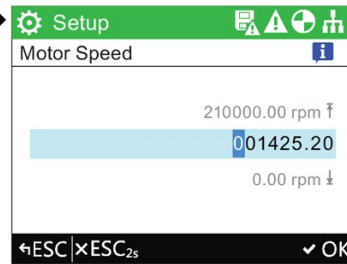

Enter Motor Speed from rating label

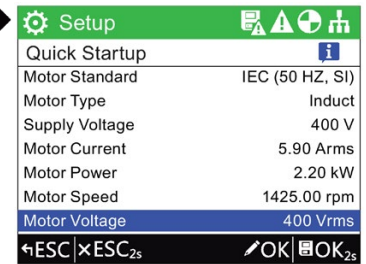

Select Motor Voltage

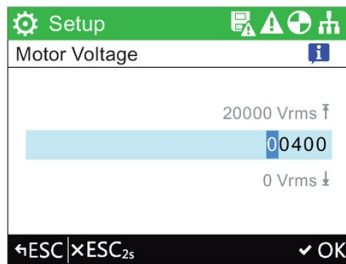

Enter Motor Voltage from rating label

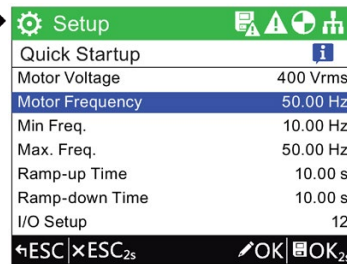

Select Motor Frequency

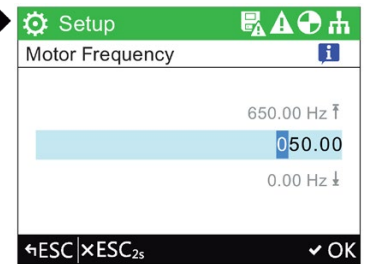

Enter Motor Frequency

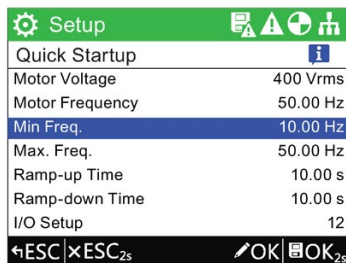

Select Min. Freq.

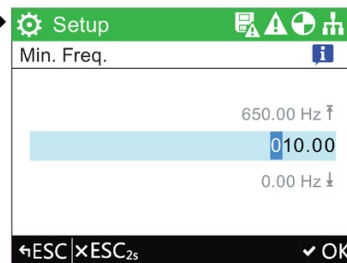

Enter the required Min. Freq.

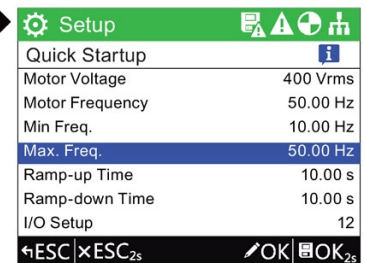

Select Max. Freq.

6.1 Example Setups

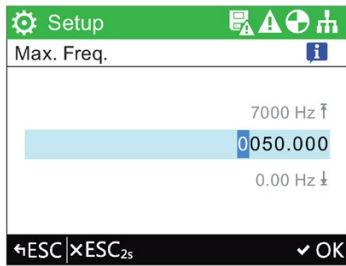

Enter the required Max. Freq.

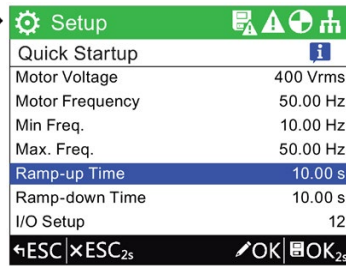

Select Ramp-up Time

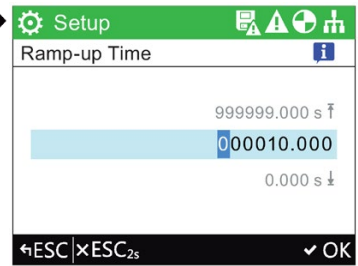

Enter required Ramp-up Time

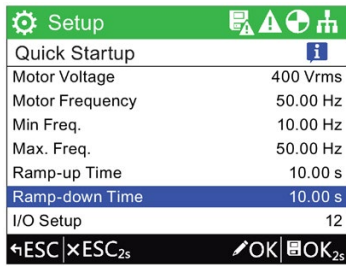

Select Ramp-down Time

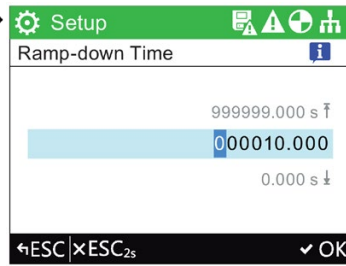

Enter required Ramp-down Time

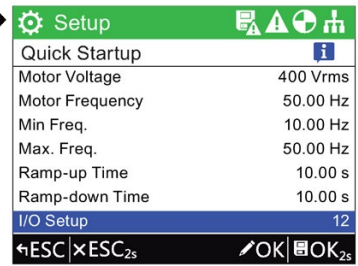

Select I/O Setup

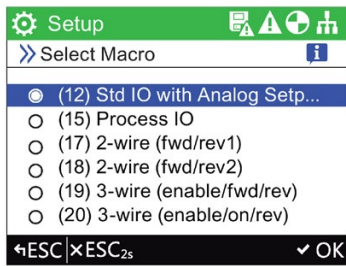

Select the required Macro

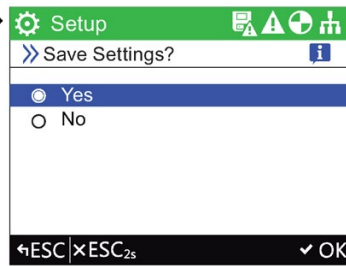

Save the Settings

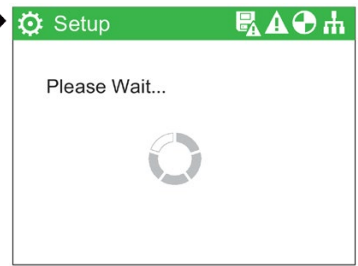

Saving Settings in progress

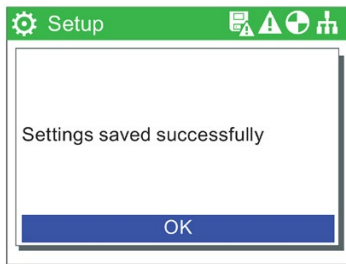

Settings have been saved

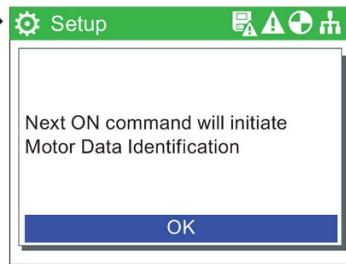

Motor ID ran on next ON command

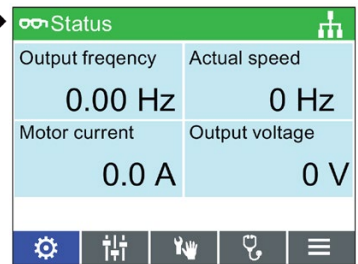

Setup up completed

6.1.2 Advanced Startup with the IOP-2

Advanced Startup overview





Advanced Startup is a commissioning process for all application which provides a high degree of flexibility when dealing with the converter settings. The provided settings allow an optimized adaption of the converter to the target application.

The setup process will guide the user through the commissioning process by presenting a number of categories where the user can choose the necessary options and values to commission the converter and motor.

At the conclusion of the setup process, the data can be saved to the converter's memory.

Setup Icons

The setup process uses a number of very important icons to indicate the status of the settings. A description of the various icons is given below.

-  The settings for the function at the default settings.
-  The settings for the function have been changed and saved.
-  The settings for the function must be checked to ensure the safety settings are correct.
-  The settings for the function must be checked and corrected if necessary.
-  This icon indicates that information is available on the selected function by pressing the INFO key.

Advanced Startup

The Advanced Startup process is outlined below and it should be remembered that the screenshots are for example purposes only and may vary from your own IOP-2 display, depending on the firmware version and the actual converter that is being commissioned.

Advanced Startup Menu

This screen lists all the advanced settings that are available for the user to modify for their specific application.

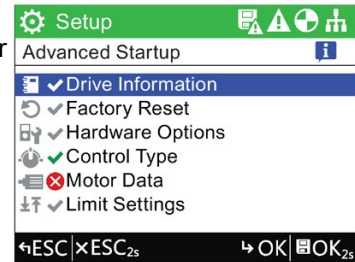

Drive Information

This screen provides general information concerning the used converter configuration (Power Module, Control Unit and the Intelligent Operator Panel IOP-2).

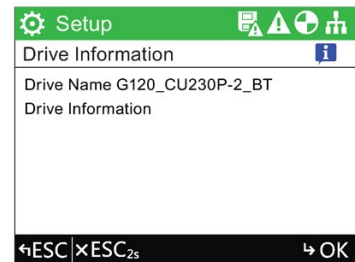

Factory Reset

This function resets all the parameters to their factory default settings. Any safety parameters that have been modified will not be reset.

It is recommended that you reset to the factory settings before commissioning the converter.

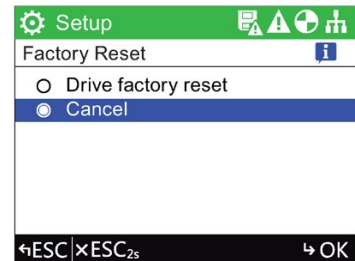

Hardware Options

This screen gives the user the opportunity to setup the converter options, for example, an Output Filter or a Braking Resistor.

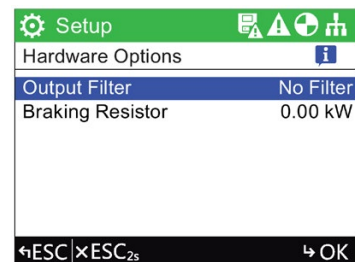

Control Type

This screen allows the application class to be set.

Depending on the particular Power Module, the converter selects the right application class and assigns the motor control the appropriate default settings.



Motor Data

The motor data stored here corresponds to the 4-pole SIEMENS standard motor with the same converter power.

For dynamic applications and when other OEM motors are in operation, adaptation of the settings will need to be made.

Setup	
Motor Data	i
Standard	IEC (50 HZ, SI)
Type	Induct
Voltage	400 V
Current	5.90 Arms
Power	2.20 kW
Speed	1425.00 rpm
Voltage	400 Vrms
←ESC ×ESC _{2s} OK	

Limit Settings

This screen give the user the opportunity to setup the dynamics settings of the motor, for example, minimum and maximum motor speed, ramp-up and ramp-down timings and OFF-3 ramp-down time.

Setup	
Limit Settings	i
Supply Voltage	400 V
Min. Freq.	10.00 Hz
Max. Freq.	50.00 Hz
Quick Stop (OFF3)	0.00 s
Ramp-up Time	10.00 s
Ramp-down Time	10.00 s
Max. Current	8.85 Arms
←ESC ×ESC _{2s} OK	

Optimisation

This screen makes is possible to optimise the converter for the technological applications and ensures that the correct motor data will be used.

Setup	
Optimisation	i
Tech. App.	Standard drive P/F
Motor Identification	MotID only standst
←ESC ×ESC _{2s} OK	

I/O Setup

This screen allows the I/O configuration to be defined. The I/O configuration is pre-assigned using macros so that no further settings are necessary.

Setup	
I/O Setup	i
Select Macro (12)	
DI 0	On/off
DI 1	Reverse
DI 2	Fault clear
DO 0	Fault
DO 1	Alarm
←ESC ×ESC _{2s} OK	

Fieldbus Setup

This screen allows the communications interface settings on the converter to be configured.

Setup	
Fieldbus Setup	i
Bus Protocol	USS
Baud Rate	38400 baud
Bus Address	0
Monitoring Time	100
USS PZD Number	2
USS PKW Number	PKW variable
←ESC ×ESC _{2s} OK	

Application Setup

This screen allows the applications specific functions to be configured. When "Application Setup" is selected, the user is presented with some default applications functions, depending on the type of Control Unit that is being used. The user can setup their own list of functions using the "Adjust function list" feature which allows functions to be added to or removed from the displayed list. A grey tick is displayed beside the functions that have not been configured using the IOP-2 and when a function has been configured using the IOP-2, a green tick is shown beside the function in the list.

If a function is removed from the list - the function will be disabled and the settings restored to the factory defaults for that specific function.

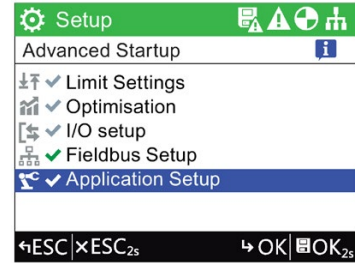

Control menu

Overview

The Control menu allows the user to change the following settings in real-time:

- Setpoint
- Reverse
- Jog
- Custom Hand mode
- Startup in Hand mode
- Hand/Auto disable

The control menu is accessed from the menu at the bottom-centre of the Status screen, as shown below.

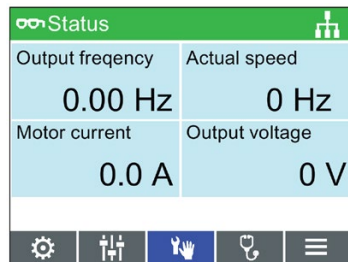

Figure 7-1 Select Control Menu

7.1 Setpoint

Setting the Setpoint

The setpoint value determines the speed at which the motor runs as a percentage of its full range of motion.

To change the setpoint, the following actions should be performed:

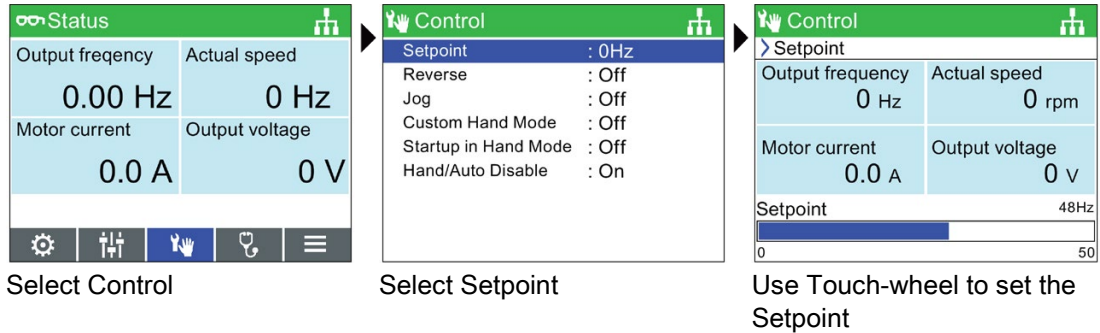

Note

Setpoint in Hertz (Hz) for SINAMICS CU230P-2

The setpoint screen by default displays the motor speed as a percentage of the total possible speed of the motor.

This behaviour changes for the SINAMICS CU230P-2 where the default setpoint value is displayed in Hertz (Hz).

7.2 Reverse

Setting Reverse

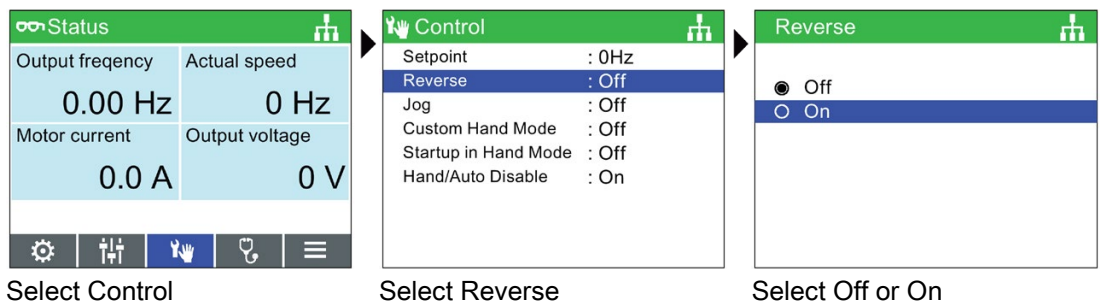

The function of the reverse command is to set the direction of rotation of the motor from its normal forward motion.

To reverse the direction of the motor, the following actions should be performed:



7.3 Jog

Setting Jog

The Jog function, when selected will allow the motor to be manually rotated by a pre-determined value with each press of . If  is pressed continuously, the motor will rotate continuously until  is released.

To enable or disable the Jog function, the following actions should be performed:

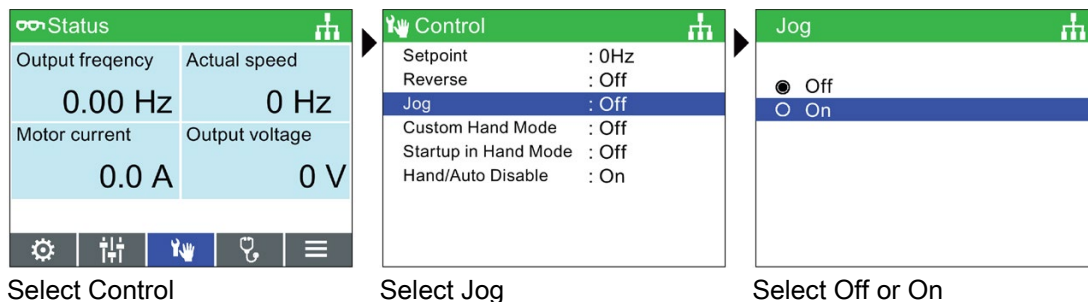

Note

Selection of Jog frequencies

It is important that the Jog parameters P1058 (Jog right) and P1059 (Jog left) are set to the required frequencies for the users application. The default jogging setpoint for both parameters is 5 Hz (150 rpm).

When the Jog left and Jog right (Jog1 and Jog 2) have been set; it is necessary to do a long press of the "INFO" key to select the other jog mode.

7.4 Custom Hand mode

Overview

The custom hand mode allows the user to setup a command source and setpoint source directly from the Intelligent Operator Panel 2 (IOP-2).

When the custom hand mode has been set, the IOP-2 Sensor Control Field can be used as the setpoint source.

The Auto mode is unaffected by any changes made by the custom hand mode function.

A breakdown of all the interconnection inputs are given in the table below.

An example of setting up the custom hand mode is given in the instructions below.

Table 7- 1 Interconnection inputs for Status Word 1 in Custom Hand mode

Standard interconnection				
r8540	STW 1 from IOP-2	Binector Inputs (BI)	p8542	Effective STW1 in Custom Hand mode
Bit0	ON/OFF key	->	Bit0	ON/OFF1
Bit1	Two quick press of the OFF key	->	Bit1	OFF2
Bit2	A long press of the OFF key	->	Bit2	OFF3
Bit3	Reserved	->	Bit3	Inhibit/enable operation
Bit4	Reserved	->	Bit4	Ramp-function generator enable
Bit5	Reserved	->	Bit5	Continue ramp-function generator
Bit6	Reserved	->	Bit6	Setpoint enable
Bit7	Alarms menu acknowledge all faults	->	Bit7	Acknowledge faults
Bit8	Jog 1 (Control menu)	->	Bit8	Jog 1
Bit9	Jog 2 (Control menu)	->	Bit9	Jog 2
Bit10	Reserved	->	Bit10	Control by PLC
Bit11	Change direction (Control menu)	->	Bit11	Direction of rotating - reversed
Bit12	Reserved	->	Bit12	Speed control enable
Bit13	Reserved	->	Bit13	Motorized potentiometer, setpoint, increase
Bit14	Reserved	->	Bit14	Motorized potentiometer, setpoint, decrease
Bit15	Reserved	->	Bit15	CDS selection
Standard interconnection				
r8541	Speed setpoint from IOP-2	Connector Inputs (CI)	p8543	Effective speed setpoint in Custom Hand mode
	N_soll OP	->		Speed setpoint

Setting up Custom Hand mode example

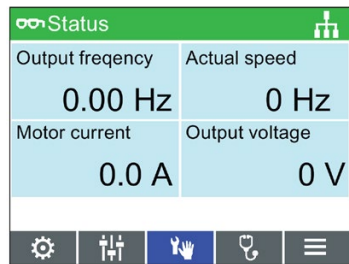

Select Control

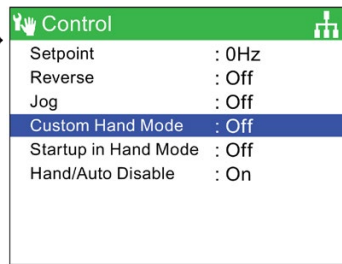

Select Custom Hand Mode



Select Custom Hand Mode On

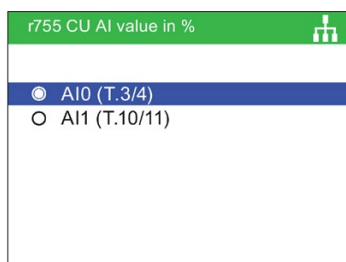
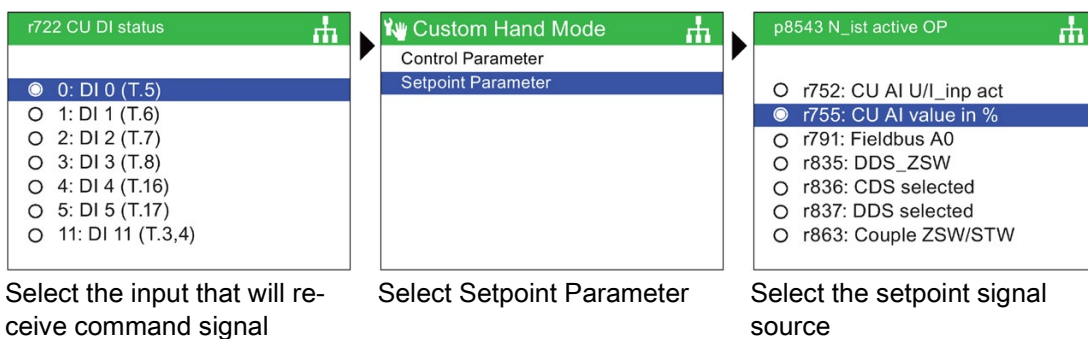
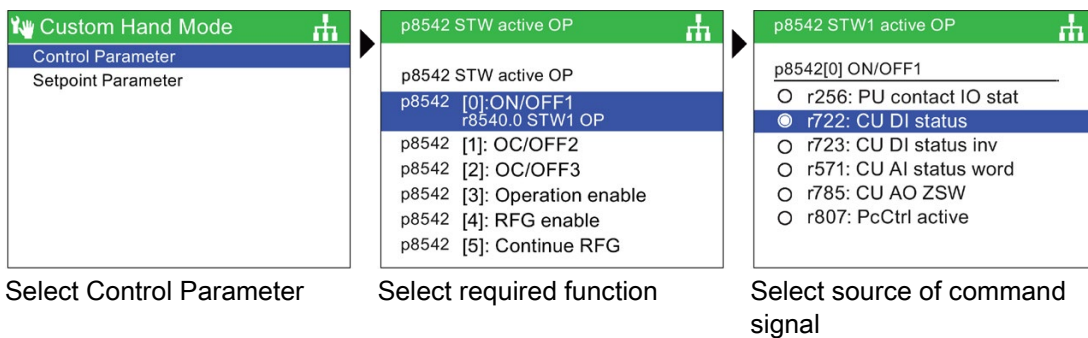

Select the input to receive the setpoint signal

Once the setpoint signal input has been selected, the IOP-2 will return to the Setpoint selection screen then press ESC for >3 secs, to return to the status screen.

In this example, the converter is now setup to receive the ON/OFF1 command from Digital Input 0 (DI0) and the speed setpoint from Analog Input 0 (AI0), from the controlling PLC.

7.5 Startup in Hand mode

Overview

Startup in Hand mode allows the converter, under the control of the Intelligent Operator Panel (IOP-2), to startup in Hand mode automatically. The command source is then taken from the off and on buttons of the IOP-2.

An example of setting up the Startup in Hand mode is given in the instructions below.

Setting up Startup in Hand mode example

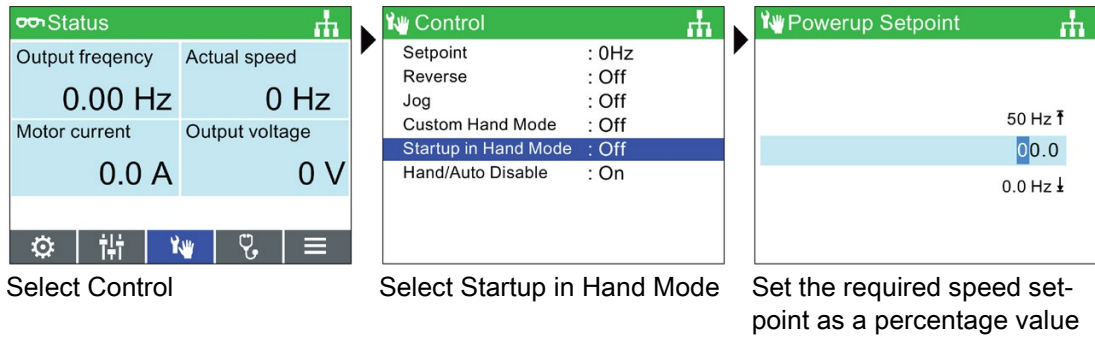

The IOP-2 will automatically return to the Control menu and show that "Startup in Hand Mode" is "On".

The converter, after a power-cycle will automatically startup in Hand mode, but the attached motor will not run until the run command is given by the buttons on the IOP-2.

7.6 HAND/AUTO disable

Overview

The HAND/AUTO disable function disables the HAND/AUTO key on the Intelligent Operator Panel (IOP-2) and pressing the key will not produce any action by the IOP-2.

An example of setting up the Hand/Auto disable mode is given in the instructions below.

Setting up the HAND/AUTO disable function

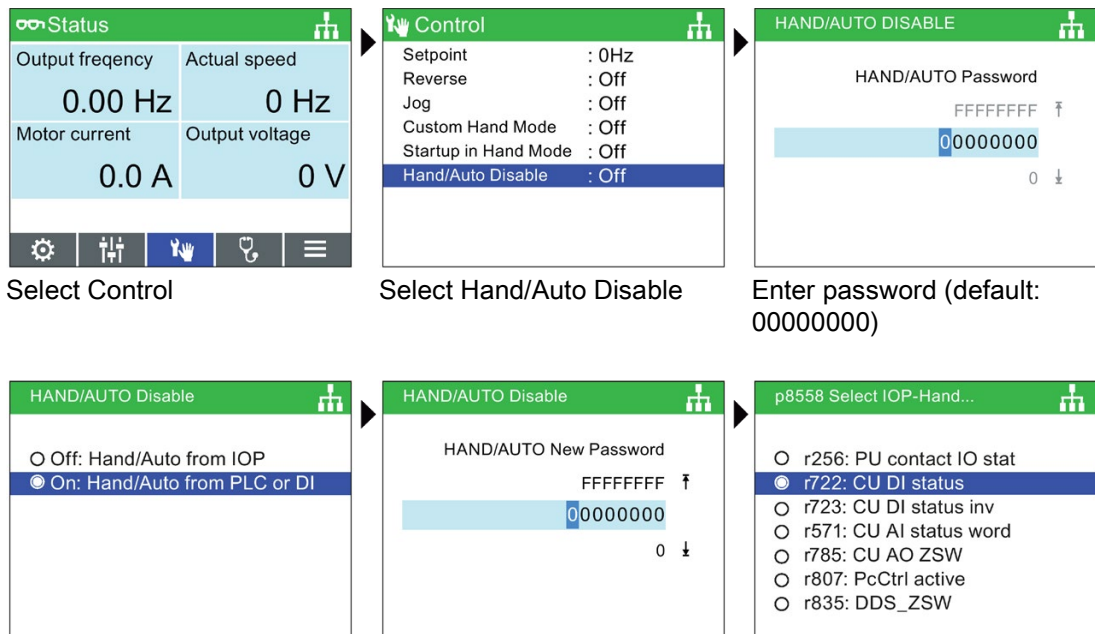

Select On: Hand/Auto from
PLC or DI

Enter password again or
create a new password

Select signal source

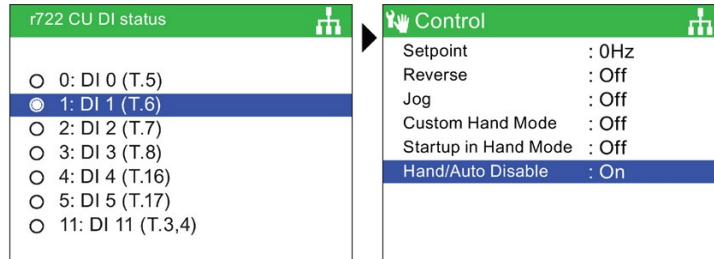

Select input to receive control
signal

Press ESC to return to Con-
trol Menu

The HAND/AUTO button is now disabled and local control of the IOP-2 cannot be activated by the HAND/AUTO button. In this example, the converter is now setup to receive the HAND/AUTO command from Digital Input 1 (DI1).

Note

Power-cycle required to complete the HAND/AUTO disable function

When the HAND/AUTO disable function is initiated the function will not become active until a power-cycle of the IOP-2 has been performed. When the HAND/AUTO disable function is turned off, again, a power-cycle of the IOP-2 is required to complete the deactivation of the function.

Menu

8.1 Menu overview

Overview

The "Menu" is selected from the five menu options at the bottom of the IOP-2 screen.

When the "Menu" option is selected the following functions are displayed:

- Wizards
- Parameters
- Diagnostic
- Up/Download
- Extras

By sliding your finger around the Sensor Control Field or using the arrow keys, the required function can be highlighted. Pushing the OK confirms the selection and further sub-menus will be displayed. Pressing ESC once will return the IOP-2 to the previous screen, a longer press will return the display to the "Status" screen.

For information on the IOP-2 compatibility, see  Introduction (Page 13).

8.2 Diagnostics

Diagnostics menu

When the diagnostic function is selected the following options are presented:

- Active faults/alarms
- History
- Identification/Maintenance
- I/O status
- Communications status
- I/O simulation
- Drive enables

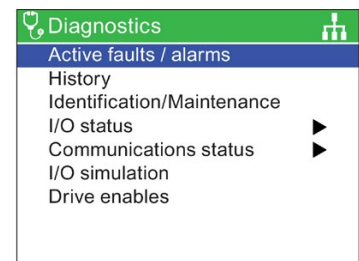

Active faults/alarms

When this option is selected the screen will display any active faults and alarms that have not yet been acknowledged.

Each fault and alarm can be selected and by pressing the INFO key or the OK key, an explanation of the fault or alarm will be displayed.

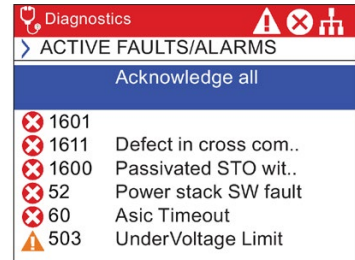

History

When this option is selected the screen will display a list of all previous faults and alarms with the time that they occurred.

Each fault and alarm can be selected and by pressing the INFO key or the OK key, an explanation of the fault or alarm will be displayed.

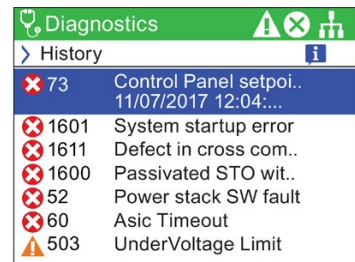

Identification/Maintenance

Displays specific technical information regarding the Control Unit and Power Module to which the IOP-2 is attached will be displayed. The actual information displayed depends on the type of Control Unit and Power Module to which the IOP-2 is connected.

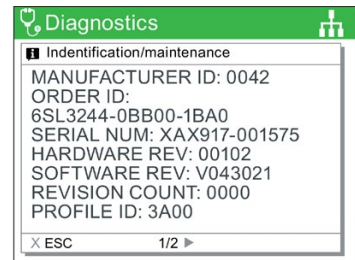

I/O status

This option displays a list of the digital and analog inputs and outputs of the converter and their current status.

This is an information screen and cannot be changed.

Pressing ESC will return the display to the previous menu.

In the example shown opposite, the status of the digital inputs are displayed.

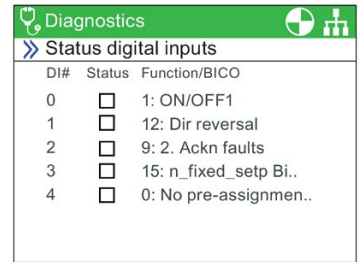
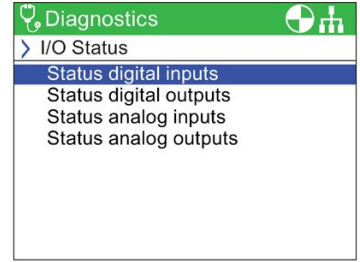

Communications status

This option displays the status of the fieldbus interface and the details of the settings for the data exchange, for example status words and control word lengths.

In the example shown opposite, the status of the fieldbus communications is shown.

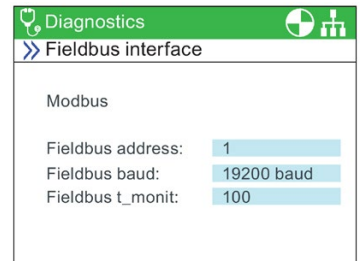
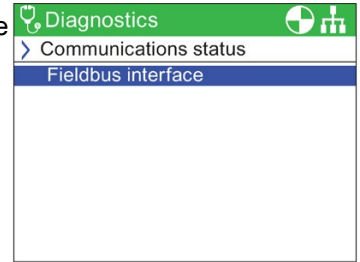

I/O simulation

! WARNING

Loss of control of the converter

If the converter is started using the I/O simulation and the IOP-2 is removed from the converter it will not be possible to stop the converter running the motor. If the I/O simulation is activated, then only the I/O simulation can be used to stop the converter.

The IOP-2 simulation screen allows digital and analog IOs to be simulated without the requirement for external signals. These features are of great benefit during commissioning and fault finding, as the user can quickly simulate a situation without using wires, tools and external equipment.

For example:

- A digital input can be made high without any wires in the terminals.
- An analog input or output can be driven to any value without any wires in the terminals.
- A simulation can be overridden and made high.

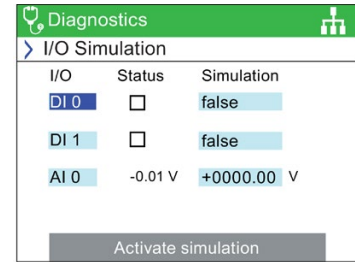

The screen presents the following options:

- I/O - Three I/Os can be simulated - two digital and one analog.
- Status - this indicates the real-time status of the input or output. If the square is shaded then the input or output signal is present. This is a read-only section of the screen.
- Control - this column of the screen displays the present status of the input or output and can be altered.

Drive enables

The drive enables screen displays a list of all the current enabling signals for the converter. If the enable signal is present and active it will be selected . If the enable signal is not present and is not active it will be unselected .

This screen is read-only and is for information purposes only.

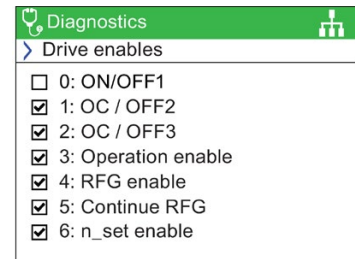

8.3 Parameters

Parameter menu

For information on IOP-2 compatibility, see  Introduction (Page 13).

The parameter menu allows the user extensive functionality and access to all the converter parameters. When this option is selected the user is given the opportunity to perform parameter orientated functions grouped in the following manner:

- Parameter groups
- Search by number
- My parameters
- Changed parameters
- Parameter filter

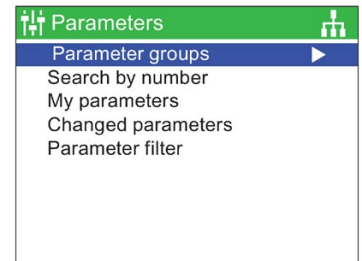
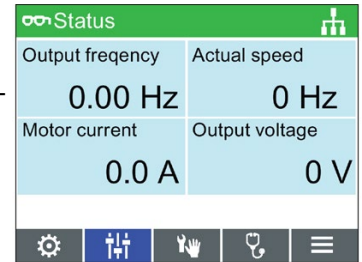

Fast scroll

When searching through any large parameter list, the Fast scroll function will automatically start when the user slides their finger around the Sensor Control Field in a fast motion. A large blue box will appear on the screen, showing the current parameter number, with each scroll the number will increase by 100. When the user stops scrolling, the parameter number nearest to the number displayed will be selected.

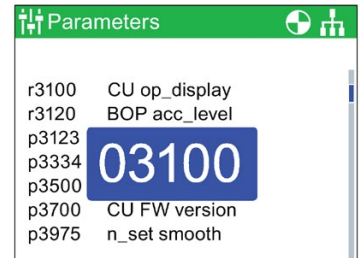

Parameter groups

All parameters

This option allows the user access to the individual parameters of the converter. The default filter is "Standard" which allows the user access to the most frequently used parameters.

Commissioning

This screen displays a complete listing of all the parameters required for quick commissioning. The parameters are listed in numerical order and can be accessed to either confirm the set values or modified should there be a need to fine tune the application or correct any errors in the parameter values.

Commissioning interface

Selects the storage medium for access via the USB mass storage.

Saving & reset

This option allows the user access to all the parameters regarding the saving and reset functions of the converter. Each parameter displays its currently set value and these can be modified if required.

System information

This screen displays all the parameters that contain system information regarding the converter. The majority of these parameters are read-only and are for information purposes only.

Basic settings

Displays the effective Drive Data Set (DDS). Each basic setting can be selected and modified if necessary.

Inputs/outputs

This option allows access to all the available parameters to configure the digital and analog I/Os.

The user can navigate through the various inputs and outputs to see the current configuration of the inputs and outputs and, if necessary access the parameters directly to modify their values.

Setpoint channels

This option allows the user to display and modify the setpoint parameters.

Operating mode

This option allows the user to display and modify the operating mode parameters.

Drive functions

This option allows the user direct access to the parameters regarding the drive functions.

It is important that if any parameters concerning the above mentioned functions are to be modified, that the converter/motor system is in a safe state prior to the parameter changes.

Communications

This option allows the user direct access to the parameters that control and configure the communications fieldbus of the converter. The parameters can be viewed to confirm their settings and values, they can also be modified if they are not read-only parameters.

Diagnostics

This option allows the user direct access to the parameters that monitor the state of the system.

All the parameters under these groupings are read-only and cannot be modified.

Search by number

This option allows the user to search for a specific parameter number.

If the parameter number does not exist, the screen will display a choice between "Select a new number" or "Go to the nearest parameter number".

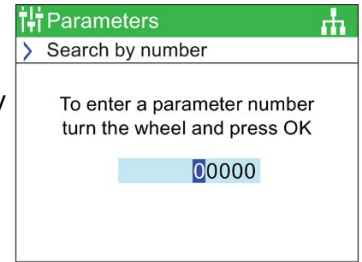

My parameters

This option allows the user to select the parameters that they wish to list. The user is presented with a list of parameters that can be selected. Once selected - only those parameters are displayed when the "My Parameters" option is selected. There are additional options that allow the user to manage their list of parameters.

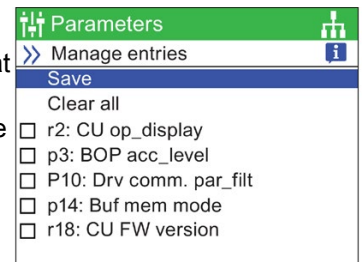

Copying the "My Parameters" list to another IOP-2

When a "My Parameters" list is created, it saves the lists in the **config.bin** file on the IOP-2.

To copy the config.bin, the following procedure should be performed:

1. Connect the IOP-2 via the USB to your PC (the IOP-2 will enter "Mass Storage" mode).
2. Navigate to the **config** folder (shown in the screenshot).
3. Copy the **config.bin** file to a suitable location on your PC.
4. Disconnect the IOP-2 and connect a new IOP-2 and copy the **config.bin** file to the new IOP-2.

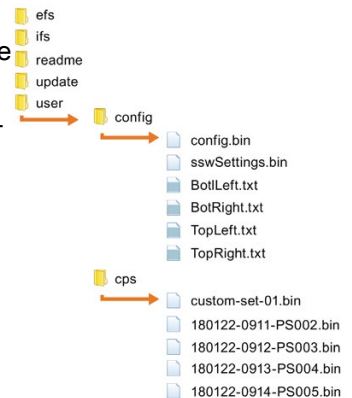

Changed parameters

When the "Changed parameters" option is selected the IOP-2 will search the converter parameter list for all the parameters that have had their values changed from the factory default settings.

Once the search is complete, the screen will present a list of all parameters that have changed values.

The individual parameters can be accessed so that their current values can be displayed and modified if necessary.

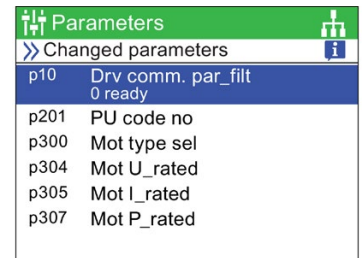

Parameter filter

This option allows the user to select the parameter access level. Standard is the default access level, which gives the user access to the most frequently used parameters. Expert level gives access to all available parameters.



8.4 Up/Download

Overview

The upload and download options allow the user to save parameter sets to the various memory storage that is available to the system.

For further information on saving, copying, cloning and creating custom parameter sets, see  Customer parameter sets (Page 59).

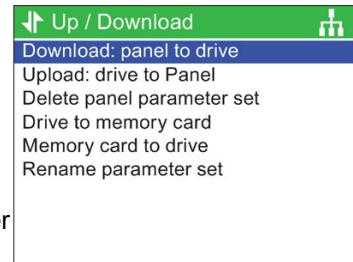

WARNING

Unexpected behaviour of converter

During the transfer of data to and from the converter, it is essential that the transfer is not interrupted and the process is allowed to be completed. If the process is interrupted, it is possible that the data could be corrupted and the system may behave in an unexpected manner. Should an interruption of the transfer process occur, then it is highly recommended that a factory reset of the converter is performed prior to any further parameterization or giving the converter control of the application.

Fault screen during up/download

If during the up/download process a fault occurs and the fault screen is displayed, press ESC if you wish the up/download to be continued. If OK is pressed, it will cancel the up/download process.

Safety Parameters

If safety parameters are to be downloaded a function test of the safety functions has to be performed. Please refer to the "Safety Integrated Function Manual" which can be found at the hyperlink below:



Safety Integrated Function Manual
<http://support.automation.siemens.com/WW/view/en/50736819>

Using the IOP-2

The IOP-2 must be handled with particular care for all SINAMICS devices that use an IOP-2 so that no malicious software or erroneous parameterizations are spread between different commissioning PCs or inverters.

 WARNING
Risk of death due to software manipulation when using exchangeable storage media Storing files onto exchangeable storage media amounts to an increased risk of infection of the commissioning PCs, e.g. with viruses or malware. Incorrect parameter assignment can cause machines to malfunction, which can lead to injuries or death. <ul style="list-style-type: none">• Protect files stored on exchangeable storage media from malicious software using appropriate protection measures, e.g. virus scanners.

 WARNING
Risk of death due to software manipulation when using exchangeable storage media Storing the parameterization (incl. Safety Integrated parameterization) on exchangeable storage media carries the risk that the original parameterization (with Safety Integrated) will be overwritten, for example, by the IOP-2 of another drive without Safety Integrated. Incorrect parameter assignment can cause machines to malfunction, which can lead to injuries or death. <ul style="list-style-type: none">• Ensure that only the IOP-2 that belongs to the respective converter is used.• Ensure that only trained or authorized personnel have access to the enclosures, cabinets or electrical equipment rooms.

8.5 Support

Overview

The Support function on the IOP-2 allows the user to access Siemens Customer Support assistance and information in a number of ways depending upon the individual requirements.

Industry Online Support

The Online Support option gives the user the ability to gather technical information about the connected whole system, or an individual component of the system, such as Order number, Serial number, firmware version, active alarms.

When the generate 2D matrix code is scanned (in the example below, using the Siemens app) the user is presented with all the available technical information for their device, for example, Serial numbers, Version numbers, FAQs, Manuals, Certificates, Product Notes, Downloads and Application examples, plus the ability to initiate a Technical Support request.

Local Siemens Partner Support

This option takes user to the Siemens online Industrial automation help site.

After completed some very simple dropdown menu selections, the contact details of the Local Siemens Partner for your region is display.

Download the Siemens App

You can download the necessary Siemens app using the menu item "Download the Siemens App" which will take you to the appropriate Siemens site that will direct the user to the correct site for either Android or iPhone Smartphone platforms.

The Siemens mobile app site is given at the link below:



Siemens mobile app (<https://support.industry.siemens.com/cs/ww/en/sc/2067>)

Industry Online Support example

A brief example of the various options are shown below:

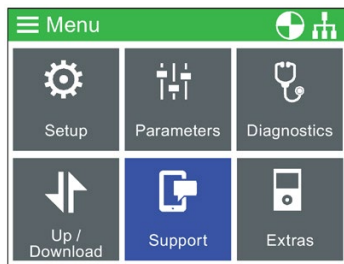

Select "Support" option from menu

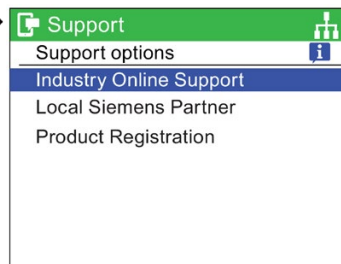

Select "Industry Online Support"

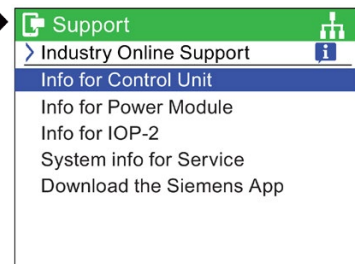

Select the information you wish to provide

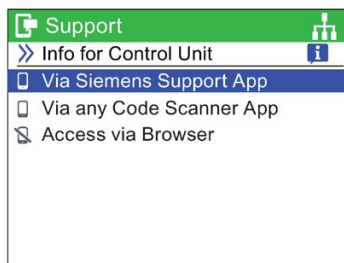

Select the device used to scan the code

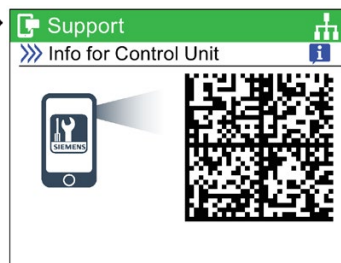

Scan the code

Once scanned with the Siemens app, the user is presented with the product information for their device. The product information includes, Serial numbers, Version numbers, FAQs, Manuals, Certificates, Product Notes, Downloads and Application examples, plus the ability to initiate a Technical Support request.

Local Siemens Partner example

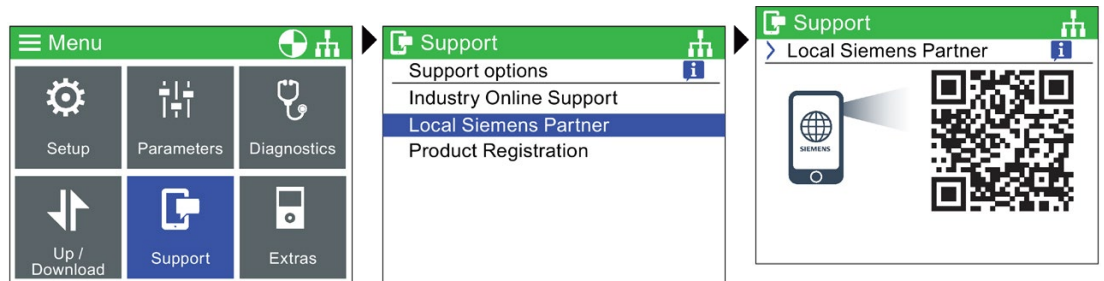

Select "Support" option from menu

Select "Local Siemens Partner"

Scan the QR code

When the QR code is scanned, the user is taken to the Siemens Industrial support site. After selecting the correct country, region, the user is given the contact details of their Local Service Partner.

Product Registration example

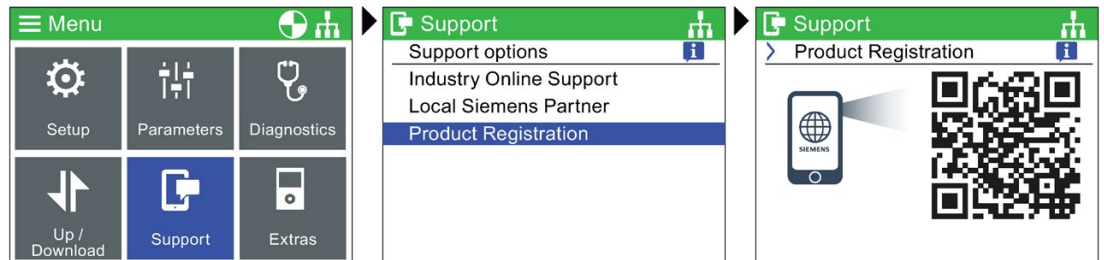

Select "Support" option from menu

Select "Product Registration"

Scan the QR code

When the QR code is scanned, the user is taken to the Siemens Industrial support site, where the registration information for your product can be entered and submitted to complete the registration process.

8.6 Customer parameter sets

Overview

Custom parameter sets can now be created and stored on the Intelligent Operator Panel (IOP-2).

The IOP-2 can store up to 255 parameter sets with customized names.

The steps to create and store a custom parameter set on the IOP-2 is given in the procedure outlined below.

Note

Custom parameter set filename limitations

Although the filename for a custom parameter set can be up to 96 characters in length, if all the filenames are 96 characters long, it will eventually limit the number of parameter sets that can be saved on the IOP-2.

This is due to the specialized nature of the IOP-2's internal memory system.

Standard parameter set access

New standard parameter sets can be uploaded from the drive to the IOP-2, these files will be stored in the "user/cps" folder on the IOP-2.

Parameter set naming convention

The IOP-2 automatically names the uploaded parameter sets using the following naming convention:

yymmdd-hhmm-PS???, where ??? is the sequential parameter set number.

When the IOP-2 is connected to a control Unit with a Real-Time Clock (RTC), it will display the parameter set filename with the current time and date stored on the IOP-2, for example, 180125-1126-PS001.

When the IOP-2 is connected to a Control Unit without a RTC, it will display the parameter set filename as yymmdd-hhmm-PS001, so only the parameter set number will be changed.

Deletion of characters or filename

When editing the filename with the on-screen keyboard the following actions should be noted:

- When the name is displayed, typing any character will append the character to the filename automatically.
 - When the filename is first displayed, the whole filename can be deleted by a two second press of the OK button.
 - If individual characters need to be deleted, then use the on-screen keyboard backspace icon.
-

Using the IOP-2

The IOP-2 must be handled with particular care for all SINAMICS devices that use an IOP-2 so that no malicious software or erroneous parameterizations are spread between different commissioning PCs or inverters.

WARNING

Risk of death due to software manipulation when using exchangeable storage media

Storing files onto exchangeable storage media amounts to an increased risk of infection of the commissioning PCs, e.g. with viruses or malware. Incorrect parameter assignment can cause machines to malfunction, which can lead to injuries or death.

- Protect files stored on exchangeable storage media from malicious software using appropriate protection measures, e.g. virus scanners.

WARNING

Risk of death due to software manipulation when using exchangeable storage media

Storing the parameterization (incl. Safety Integrated parameterization) on exchangeable storage media carries the risk that the original parameterization (with Safety Integrated) will be overwritten, for example, by the IOP-2 of another drive without Safety Integrated. Incorrect parameter assignment can cause machines to malfunction, which can lead to injuries or death.

- Ensure that only the IOP-2 that belongs to the respective converter is used.
- Ensure that only trained or authorized personnel have access to the enclosures, cabinets or electrical equipment rooms.

Creating a custom parameter set

This procedure makes the following assumptions:

- The user is conversant with the copying and renaming of files in the Windows environment
- The user is conversant with commissioning the converter
- The user has already changed all the relevant parameters for their application

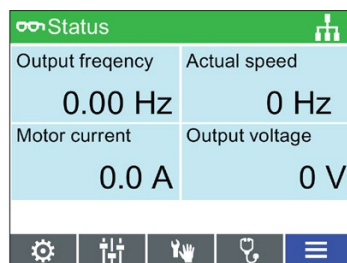

Select Menu

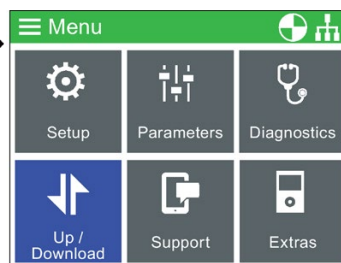

Select Up/Download

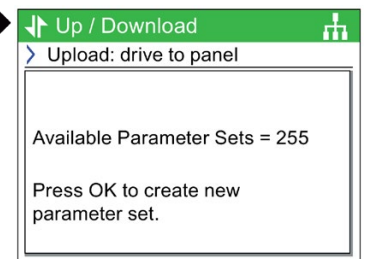

Select Upload: Drive to Panel

8.6 Customer parameter sets

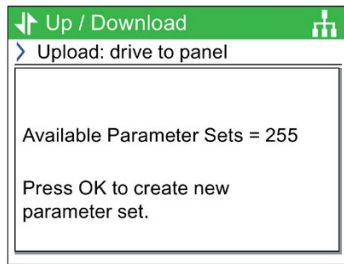

The number of available parameter sets are displayed

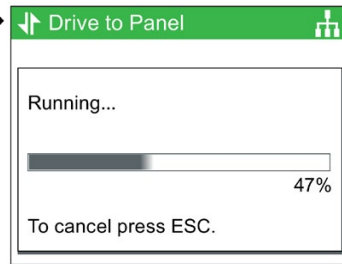

The drive parameter settings are uploaded

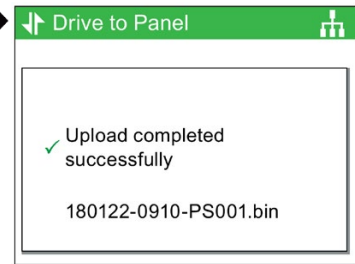

The filename of the parameter set is displayed

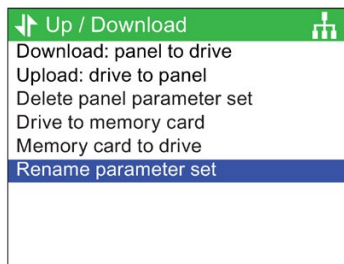

Select rename parameter set

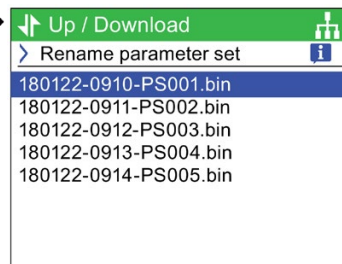

Select the parameter set to be renamed

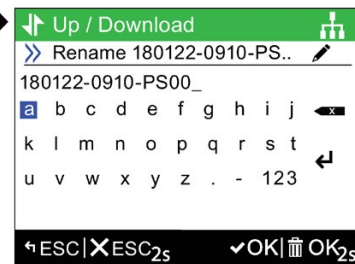

Rename the file using on-screen keyboard

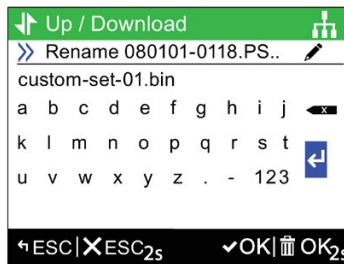

Select return icon to accept new name

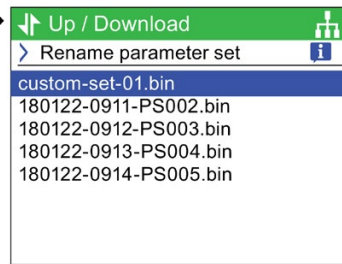

The new file name is displayed

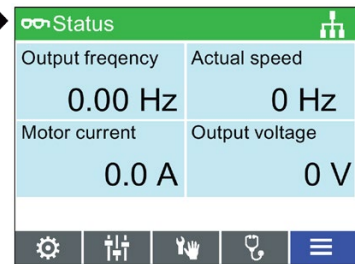

Long press of ESC returns user to Status Screen

Copying IOP-2 parameter sets and configuration data

⚠ WARNING

Risk of death due to software manipulation when using exchangeable storage media

Storing files onto exchangeable storage media amounts to an increased risk of infection of the commissioning PCs, e.g. with viruses or malware. Incorrect parameter assignment can cause machines to malfunction, which can lead to injuries or death.

- Protect files stored on exchangeable storage media from malicious software using appropriate protection measures, e.g. virus scanners.

 WARNING
<p>Risk of death due to software manipulation when using exchangeable storage media</p> <p>Storing the parameterization (incl. Safety Integrated parameterization) on exchangeable storage media carries the risk that the original parameterization (with Safety Integrated) will be overwritten, for example, by the IOP-2 of another drive without Safety Integrated. Incorrect parameter assignment can cause machines to malfunction, which can lead to injuries or death.</p> <ul style="list-style-type: none"> • Ensure that only the IOP-2 that belongs to the respective converter is used. • Ensure that only trained or authorized personnel have access to the enclosures, cabinets or electrical equipment rooms.

The IOP-2 file structure has been designed to allow the easy copying of parameter sets and other configuration data from one IOP-2 to another by using the Windows File Explorer function.

This is accomplished by simply copying the "user" folder from the IOP-2 to any number of other IOP-2 operator panels. The IOP-2 file structure is shown below.

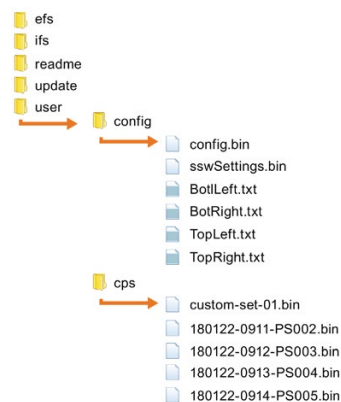

Figure 8-1 File structure of the IOP2

The "config" folder contains all the settings that have been changed on the IOP-2 itself, for example, the language settings, lighting duration and the date/time settings, etc.

The "cps" folder contains all the downloaded or customised parameters sets and the text files used for customising the screen labels when using the Screen Wizard.

Copying specific parameter sets

When you have saved a number of parameter sets to an IOP-2, it is possible to copy your saved parameter sets to another IOP-2 using the simple process outlined below.

1. Connect the IOP-2 via the USB connector to a PC.
2. The IOP-2 will enter the "Mass Storage Device" Mode.
3. On the PC, navigate to the "user/cps" folder.
4. Select the parameter sets you require and save them to a new folder on the local drive of the PC.

5. Disconnect the IOP-2 from the PC.
6. Connect another IOP-2 and copy the saved parameter sets to the "user/cps" on the new IOP-2.

This procedure can be repeated for any number of IOP-2s.

8.7 Extras Menu

Overview

The Extras menu presents a number of options for the configuration of the IOP-2, these are explained in this section.

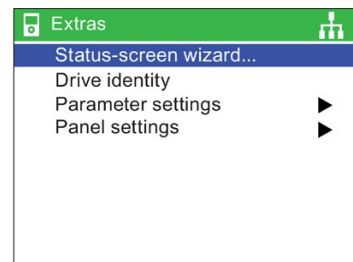

Status-screen wizard

Scalar value

The bar graph (default status screen) and the Scalar value are setup using a similar procedure. The example below show how to setup the Scalar value status screen.

Note

Scalar view limits for the SINAMICS G110D

Normally, four values can be displayed on the IOP-2 in scalar view, but when using the IOP-2 in conjunction with the SINAMICS G110D only two values can be displayed on the IOP-2 screen.

The status-screen wizard allows the user to configure the information displayed on the status screen. By default it displays output voltage and output frequency of the converter. These can be changed by using the wizard to select other physical values of the converter. Displayed units of value can be specifically adapted using known conversion factors and with the addition of an offset value to allow the units of measure to be displayed as required for the users application.

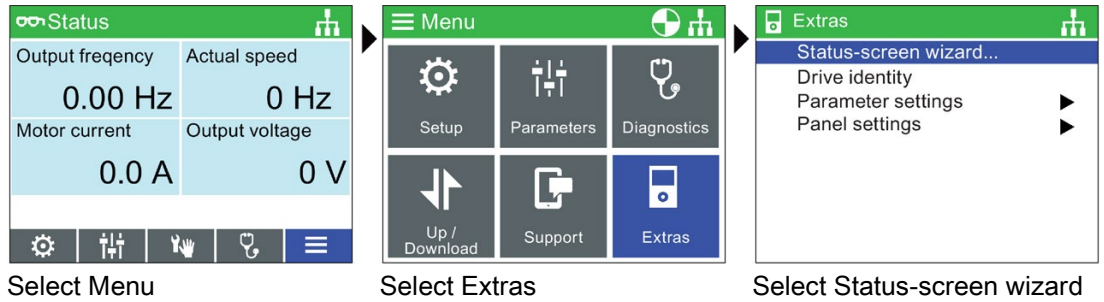

Select Menu

Select Extras

Select Status-screen wizard

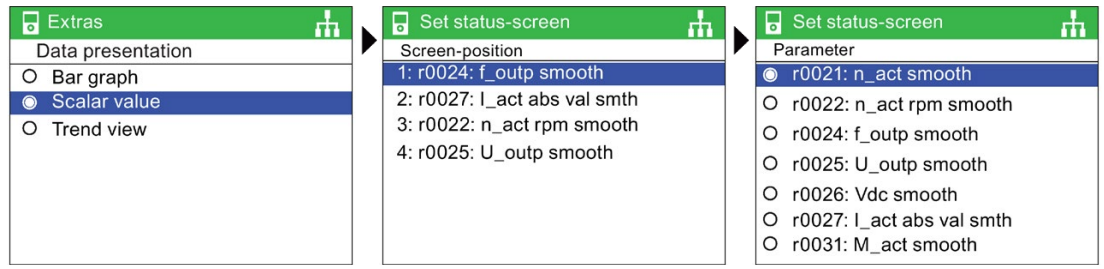

Select Scalar value

Select the screen position of the values or select "Empty" to leave it blank

Select the parameters to be displayed

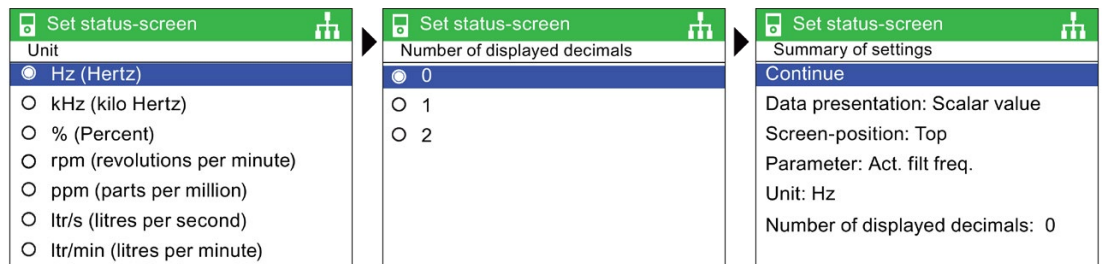

Select the unit of measure

Select the decimal places

Confirm settings

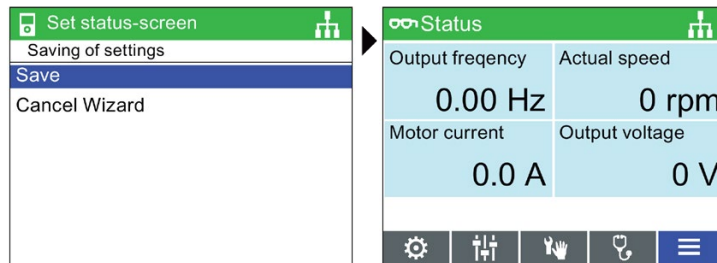

Save settings

Scalar status screen displayed

The Scalar view Status screen will change the size and position of the information shown on the IOP-2 depending on the number of values that are displayed. In the figure below, the various screen display options are shown.

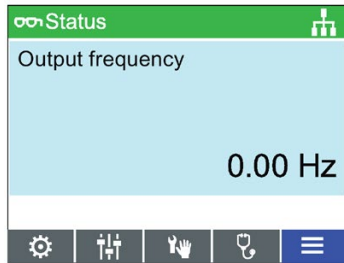

Scalar display 1 value

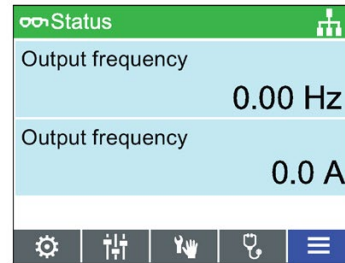

Scalar display 2 values

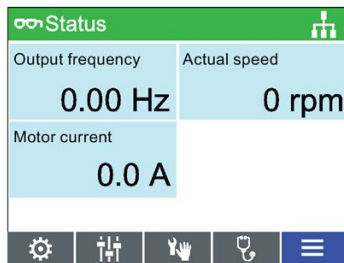

Scalar display 3 values

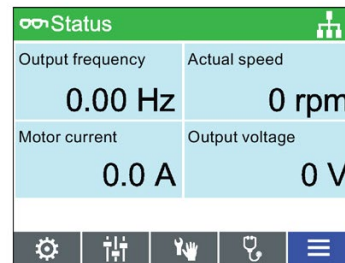

Scalar display 4 values

Figure 8-2 Status screen Scalar views

Trend view

The Trend view allows the user to configure real-time monitoring of the converter and display the desired values in the form of a graph. To setup the Trend view, the following steps should be performed.

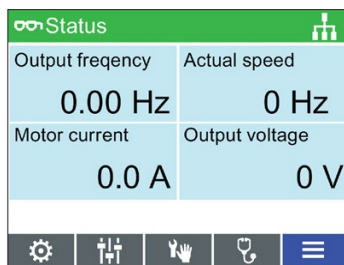

Select Menu

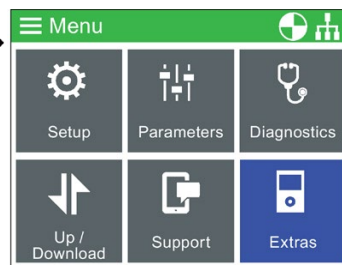

Select Extras

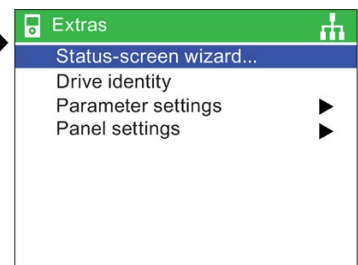

Select Status-screen wizard

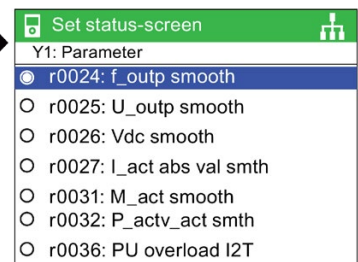
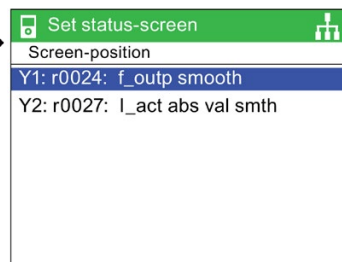
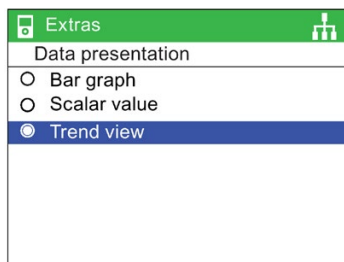

Select Trend view

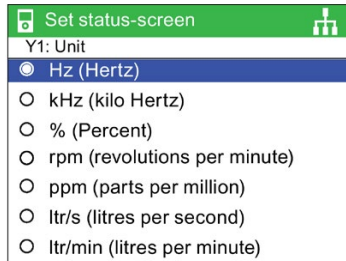

Select Unit of measure

Select screen position

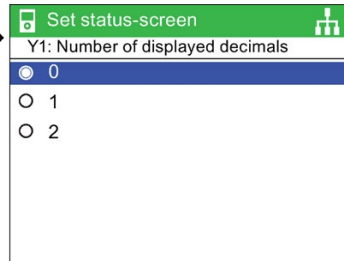

Select decimal places of displayed values

Select parameter to be displayed

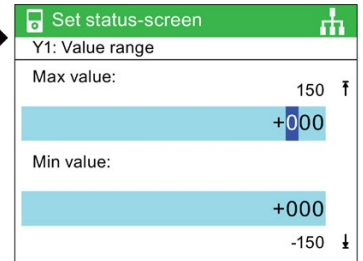

Select value range

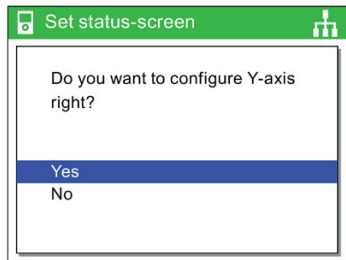

Configure Y-axis

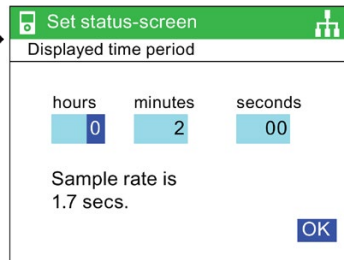

Configure displayed time period

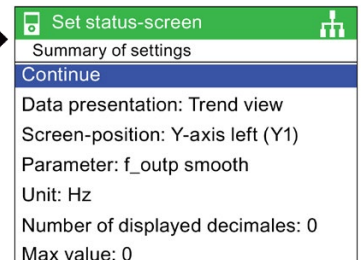

Select Continue

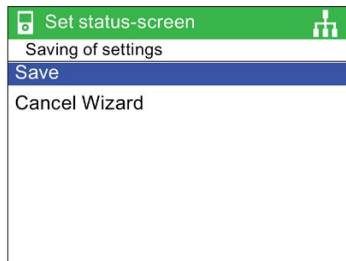

Save settings

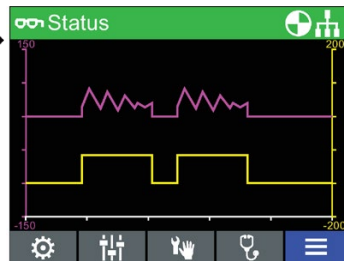

Status screen displayed with Trend view

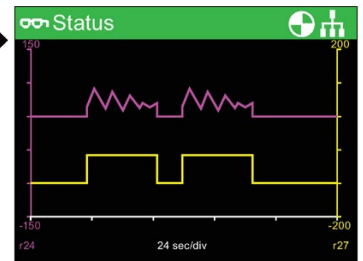

Press ESC to hide menu icons

View mode is activate by a long press of the OK button, when in Trend View. A vertical line will appear on the screen like an oscilloscope and allows the user to measure any given point on the graph by rotating the Sensor Control Field left or right. With a long press of the **INFO** button, the graph data is written to a Trend information file on the IOP-2. An example of the Trend information file and its location is given in the figure below.

```

Trend Information
-----
Template:
Axis:Param Number<index><bit>:Param Name

Left axis (Y1): r0021      : - : Act. filt. freq.
Right axis(Y2): r0025      : - : Act.outp. volt

Time period: 150 Secs.
Sample rate: 1.5 Secs.

Sample  Y1(Hz)      Y2(V)
-----
1        0.000      17.920
2        0.000      20.233
3        0.000      20.234
4        0.954      27.541
5        3.240      43.577
6        3.497      44.495
7        5.325      58.811
8        6.497      65.728
9        4.832      50.322
10       0.000      20.143
11       0.000      20.240
12       0.000      20.240
13       3.046      42.973
14       6.772      70.384
15      10.342      94.288
16      13.492     116.783
17      13.998     120.530
18      13.998     120.532
19      13.998     120.533
20      13.998     120.535
21       9.169      82.063
22       0.000       0.000
23       0.000       0.000
24       0.000       0.000
    
```

To access the Trend Information file, navigate to the following directory on the IOP:
/efs/health/TrendSample.txt

Figure 8-3 Trend information file

Drive identity

This option allows the user to display the technical details of the components that comprise the converter system. This includes the details of the Control Unit and Power Module. This is a read-only screen and cannot be modified.

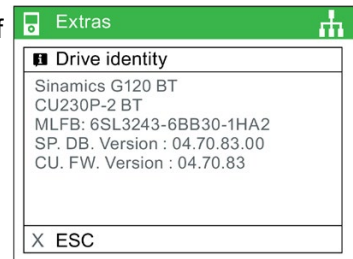

Parameter settings

Drive factory reset

There are two factory reset options:

Factory reset - This option reset all parameters to their factory default settings. Any safety parameters that have been modified will not be reset.

Safety factory reset - This option resets all the safety parameters back to the factory default settings. No other parameters will be changed.

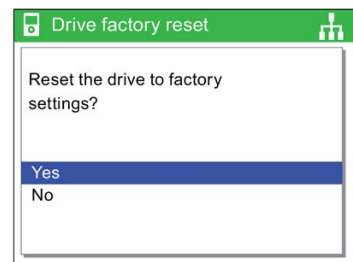

Default dataset

This option allows the user to determine which is the default command dataset when viewing or selecting a new default dataset from the options provided.

Note:

Some applications require that both command datasets be used at the same time. On the IOP-2 to access the parameters for both command datasets, then the command datasets screen must be set to "No default Command Dataset".

If the IOP-2 is not set to "No default Command Dataset" then only one command dataset will be visible to the IOP-2 in the parameter settings.

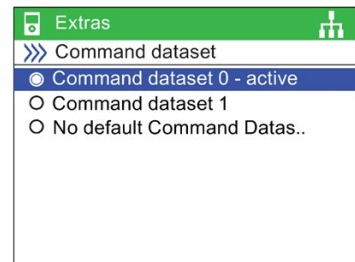
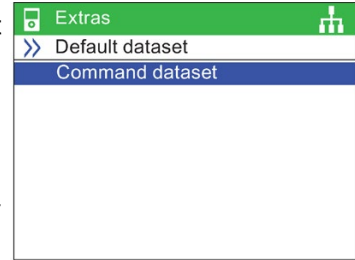

Parameter saving mode

This option allows the user to set the default location for any save function performed on the converter.

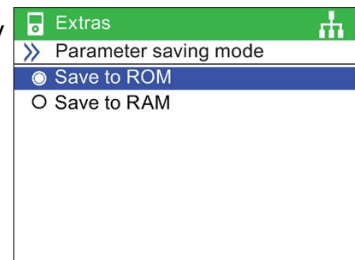

Save RAM to ROM

This option allows the user to manually save all drive data from the converters internal memory to the internal non-volatile memory - thus data save will be retained within the converter until it is overwritten.

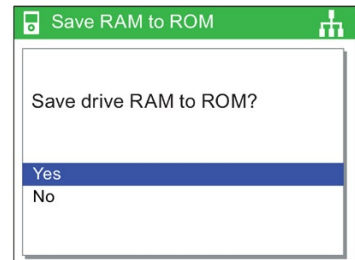

Panel settings

Language

This option allows the user to select the language that is used to display information and text on the IOP-2. This option has been previously described in the initial set-up section of this manual. Languages can be added or deleted using the USB connection on the IOP-2 and a PC.

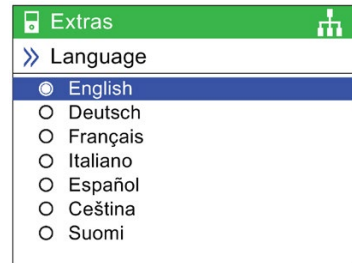

For details of selecting this function see  Initial set-up (Page 22)

Time and date settings (including Daylight savings time)

If the CU to which the IOP-2 is fitted has a real-time clock, then the option to set the correct date and time (including daylight savings time is presented in the "Panel settings" menu.

The Time and date settings allow you to setup up the following:

- **Date format-** This allows the date format to be select either DD/MM/YY or MM/DD/YY.
- **Time and date settings-** This allows the user to set the required date and time of the internal real-time clock of the Control Unit.
- **Daylight saving time-** This allows the user to setup the daylight saving time difference on the Control Unit (CU230P-2) real-time clock. The daylight saving time is set to take into account not only the time difference but also the date and time of the change to and from daylight saving time. The setup of the DST function is shown in the following procedure.

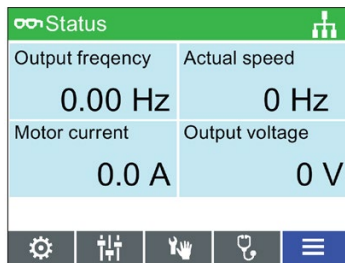

Select Menu

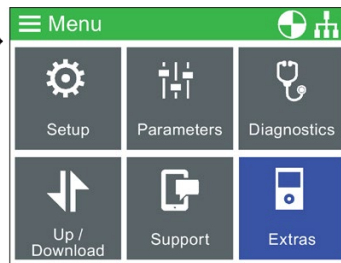

Select Extras

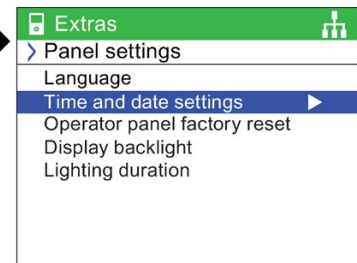

Select Time and date settings

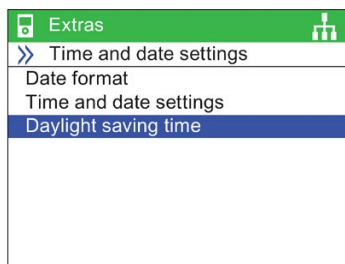

Select Daylight saving time

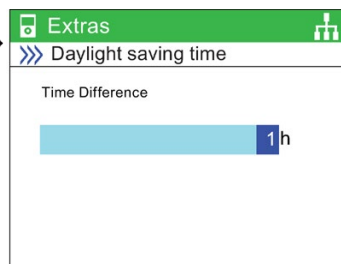

Set DST time difference

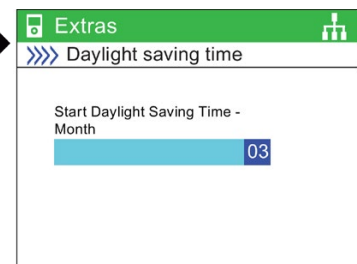

Set month DST starts



Set week DST starts

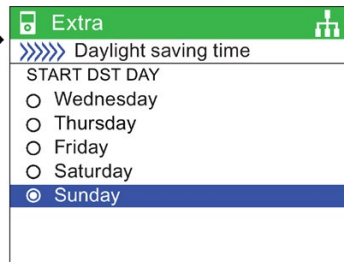

Set day DST starts

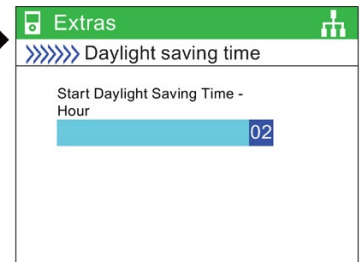

Set time DST starts



Set month DST ends



Set week DST ends

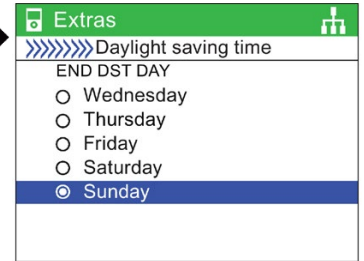

Set day DST ends

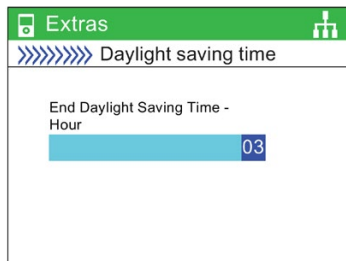

Set time DST ends

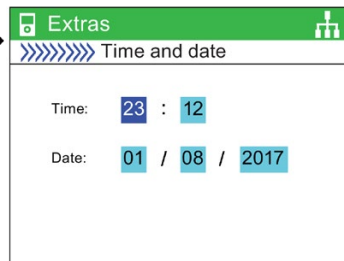

Set date and time

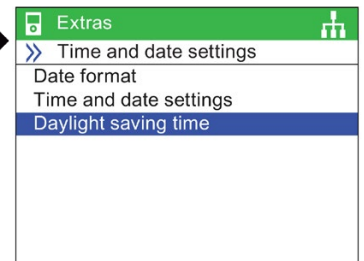

IOP-2 returns to previous screen (this may take a few seconds)

Operator panel factory reset

This option resets the IOP-2 to its default factory settings. All previous settings stored on the IOP-2 will be lost. Any parameter sets stored on the IOP-2 will not be deleted.

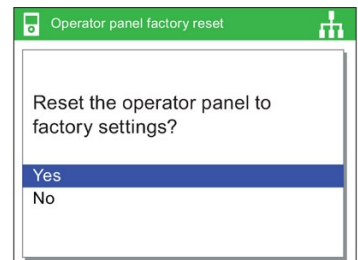

Display backlight

This option allows the user to change intensity of the display lighting.

For details of selecting this function see  Initial set-up (Page 22)



Lighting duration

The backlight display, by default, is set to automatically turn off after 60 seconds from the last key press. This time can be adjusted to 30 seconds, 60 seconds, 300 seconds or permanently on.

For details of selecting this function see  Initial set-up (Page 22)

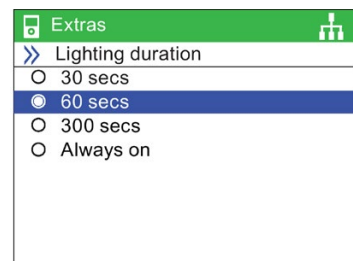

Panel identity

The panel identity screen displays the following technical information regarding the IOP-2:

- IOP-2 firmware version
- Bootloader version
- menu description version
- Parameter description version
- Menu texts version
- Parameter name index version
- Wizard description version.

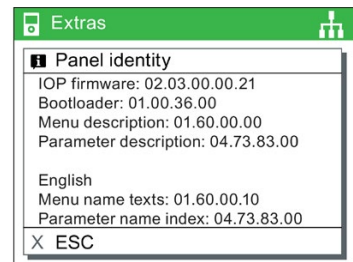

Options

9.1 Door mounting kit

Door mounting kit

To allow the IOP-2 to be mounted into the door of a cabinet, the door mounting kit (DMK) has been designed. This will allow the IOP-2 to be fitted to the front of a panel or door and be IP54 rated.

The fitting of the DMK is accomplished as shown in the figure below.

Prior to the installation of the DMK, it is necessary to create a hole in the panel or cabinet with the dimensions as shown in the figure below:

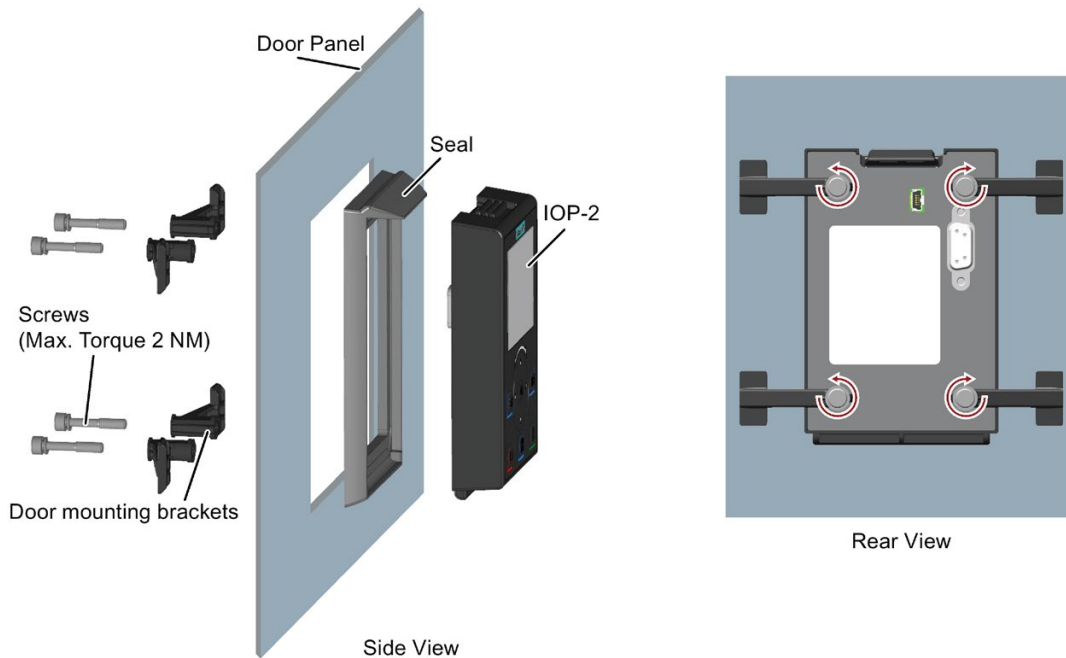
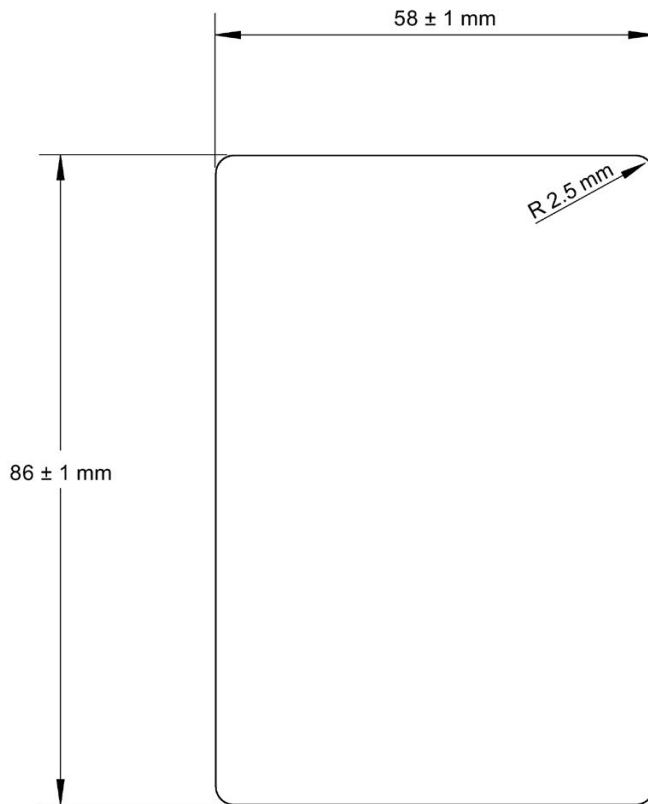

Figure 9-1 Installation of Door mounting kit

9.1 Door mounting kit



Scale 1:1

Notes:

1. The page must be printed at full size to maintain the 1:1 scale.
2. When printing from a PDF file do not select the "fit to page" option as this will reduce the page to 97% of the true size.

Figure 9-2 IOP-2 DMK drill pattern (Scale 1:1)

The depth of the panel or cabinet door should be between 1 mm to 3 mm

The IOP-2 Door Mounting Kit can be ordered using the following order number:

6SL3256-0AP00-0JA0

The DMK contains the following items:

- Door seal
- Door mounting brackets (x 4)
- Retaining screws (x 4)
- RS232 cable (5 m)

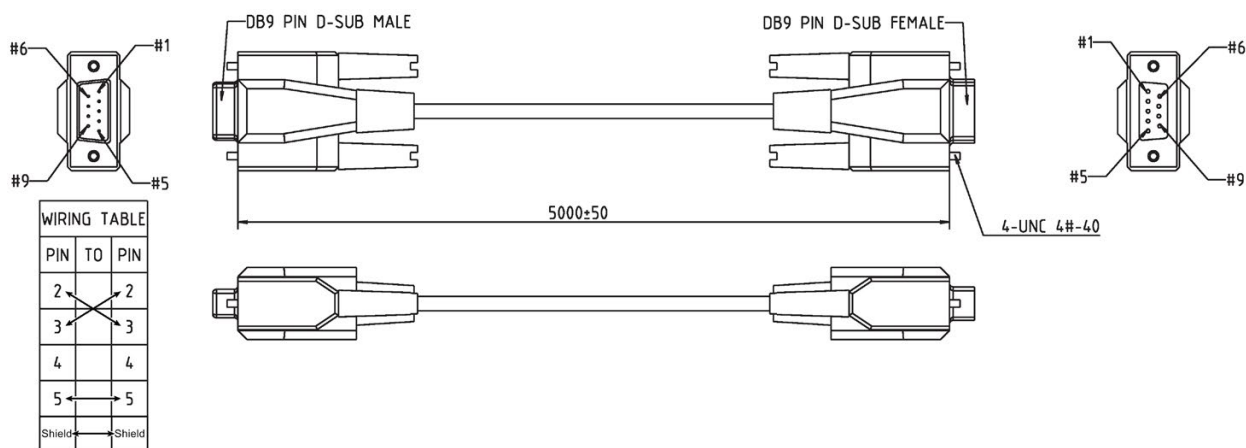



Figure 9-3 Standard RS232 null-modem cable Specifications

9.2 Hand-held device

Hand-held device

 WARNING
<p>Charging unit</p> <ul style="list-style-type: none"> • The charging unit for the rechargeable batteries is contained within the hand-held device for the sole purpose of charging rechargeable batteries. • The charging unit contained within the hand-held device should not be used with standard "AA" batteries as this will result in damage to the batteries and the hand-held device. • Only the supplied power supply unit should be used with the IOP-2. The use of any other power supply units could seriously damage the hand-held kit.

 CAUTION
General precautions <ul style="list-style-type: none">• There is a risk of explosion if battery is replaced by incorrect type.• Overcharging, short circuiting, reverse charging, mutilation, or incineration of the cells and the batteries must be avoided to prevent one or more of the following occurrences; release of toxic materials, release of hydrogen and/or oxygen gas, rise in surface temperature.• If a cell or a battery has leaked or vented, it should be replaced immediately using protective gloves.• If and when necessary, these cells or batteries must be replaced with identical new ones from the same manufacturer. If a cell or a battery to be replaced is connected with other cells or batteries in series, it is recommended that the other cells or batteries be replaced with new ones at the same time.• Battery compartments containing these cells or batteries must be provided with means of ventilation to prevent possible accumulation of any released gases under abnormal conditions.

Note

Battery lifetime

With the supplied rechargeable batteries in a fully-charged state they should last for approximately 10 hours; the use of normal "AA" batteries may last considerably less time.

Industrial environment

The IOP-2 has been designed for use within a Class A Industrial environment only.

Disposal of batteries

The batteries supplied with the IOP-2 must be disposed of in accordance with local and national environmental policies.

Battery status

The battery status is displayed at the top right-hand corner of the IOP-2 display.

Battery charging

If the batteries are put on charge and the batteries are fully discharged; the charging unit will enter a 'pre-charge' state. During the pre-charge state the LED will not be lit, therefore there may be a delay before the charging LED lights up.

The IOP-2 has no internal power source, so to increase the IOP-2's versatility, the hand-held device has been designed.

The complete list of converters that work with the IOP-2 are listed in  Introduction (Page 13). The following list comprises the converters that require the hand-held kit because the IOP-2 cannot be mounted directly on the converter:

- SINAMICS G120D-2 CU240D-2
- SINAMICS G120D-2 CU250D-2
- SINAMICS ET 200pro FC-2

- SINAMICS G110D
- SINAMICS G110M

Table 9- 1 Hand-held device order information

Order number	Item quantity	Item	Remarks
6SL3255-0AA00-4HA1	1	IOP-2	
	1	Hand-held module	
	1	Power supply unit	
	4	Rechargeable batteries	1.2 V 2100 mAh NiMH (see note below)
	1	RS232 cable	3 m

Note

Battery order information

The batteries supplied with the IOP-2 Hand-held Kit should be replaced with exactly the same type of batteries. The batteries that have been tested for use with the IOP-2 are given below:

Company: GP Batteries

Order Number: GP210AAHC



The batteries can be ordered from the following website: GP Batteries (<http://www.gpbatteries.com/INT/index.php>)

The layout of the IOP-2 hand-held device is shown in the figure below.

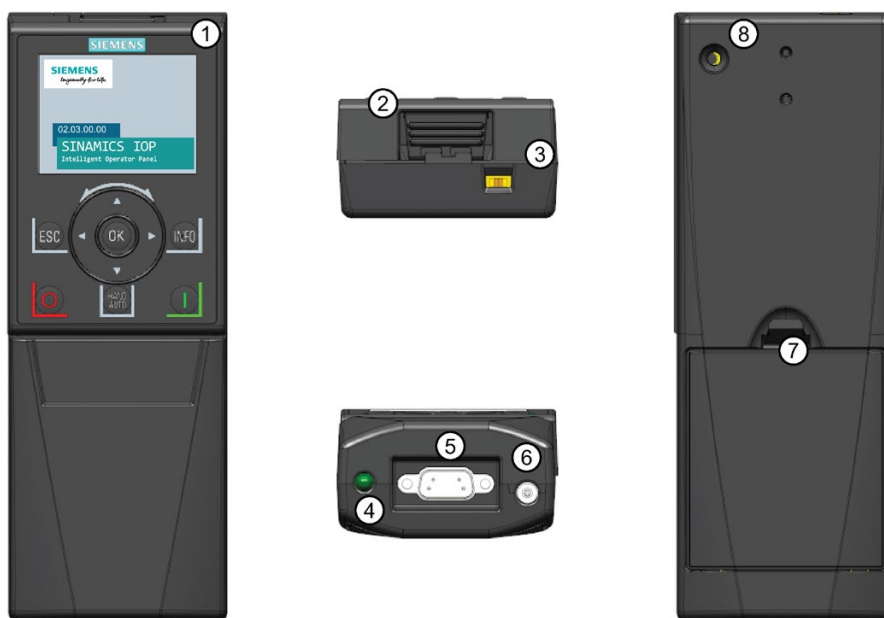

Figure 9-4 IOP-2 Handheld kit layout

1. Intelligent Operator Panel (IOP-2)
2. IOP-2 release catch
3. ON/OFF switch
4. Charging LED - ON when charging, OFF when charged
5. 9-pin Sub-D male connector (RS232)
6. Charging unit input
7. Battery compartment cover
8. IOP-2 retaining screw

Fitting the batteries

The hand-held device is powered by four 'AA' rechargeable batteries; these batteries are supplied with the hand-held kit. The batteries are fitted as shown in the figure below.



Figure 9-5 Installing batteries for handheld kit

Technical data

10.1 Technical specifications

IOP-2-2 Technical data

Table 10- 1 IOP-2 and Door mounting kit specifications

Feature	IOP-2 only	Door mounting kit
Protection	Depending upon the Control Unit IP rating to a max. of IP55 / UL Type 12 enclosure	
Dimensions (HxWxD)	106.86 mm x 70 mm x 19.65 mm (Depth includes width of wheel)	
Net weight	0.134 Kg (0.295 lbs)	
Gross weight	0.206 Kg (0.454 lbs) - Includes packaging	
Screw torque	-	Max. 1 Nm to 1.25 Nm
Operating ambient temperature	0 - 50 °C (32 - 122 °F) when directly connected to the converter. 0 - 55 °C (32 - 131 °F) when using the Door Mounting Kit.	
Transport and storage ambient temperature	-40 - +70 °C (-40 - 158 °F)	
Humidity	Relative humidity <95% non-condensing	

Table 10- 2 Hand-held specifications

Feature	IOP-2 Hand-held kit
Protection	IP20
Dimensions (HxWxD)	195.04 mm x 70 mm x 37.58 mm
Net weight	0.724 Kg (0.1.59 lbs)
Gross weight	0.970 Kg (2.14 lbs) - Includes packaging
Operating ambient temperature	0 - 40 °C (32 - 104 °F) [charging 10 - 40 °C]
Transport and storage ambient temperature	-20 - +55 °C (-4 - 131 °F)
Humidity	Relative humidity <95% non-condensing

Index

"

"config" folder, 63
"cps" folder, 63

A

Active faults/alarms, 50
Advanced Startup, 37
AUTO mode, 15

C

Changed parameters, 55
cloning, 56
Communications status, 51
Control
 Jog, 43
 Jog frequencies, 43
 Reverse, 42
copying, 56
custom parameter sets, 56

D

Datasets, 29
Daylight savings time, 70
DEMO mode, 16
Diagnostics menu, 49
 Active faults/alarms, 50
 Communications status, 51
 Drive enables, 52
 History, 50
 I/O simulation, 51
 I/O status, 51
 Identification/Maintenance, 50
Display backlight, 26
Door mounting kit, 73
Drive Datasets, 29
Drive enables, 52

E

Extra menu
 Drive identity, 68

Panel settings, 70
Status-screen wizard, 64
Extras menu, 64

F

file structure, 63
Firmware version, 5
functional support, 14

H

HAND mode, 15
Hand/Auto disable, 46
Hand-held device, 75
Hand-Held Kit, 13
History, 50

I

I/O simulation, 51
I/O status, 51
Identification/Maintenance, 50

J

Jog, 43
Jog frequencies, 43

K

Key
 ESC, 15
 INFO, 16
 OFF, 15
 ON, 15
Keypad
 Locking, 16
 unlocking, 16

L

Language selection, 23
Lighting duration, 25

M

- Macro source selection, 32
- Menu, 49
- Menu Overview, 49
- Menu structure, 19
- My parameters, 55

P

- Panel settings
 - Display backlight, 72
 - Language, 70
 - Lighting duration, 72
 - Operator panel factory reset, 71
 - Panel identity, 72
- Parameter filter, 56
- Parameter groups
 - All parameters, 53
 - Commissioning, 53
 - Commissioning Interface, 54
 - Communications, 54
 - Diagnostics, 54
 - Drive functions, 54
 - IBasic settings, 54
 - Inputs/Outputs, 54
 - Operating mode, 54
 - Saving & reset, 54
 - Setpoint channels, 54
 - System Information, 54
- Parameter menu
 - Changed parameters, 55
 - My parameters, 55
 - Parameter groups, 53
 - Search by number, 55
- Parameter settings, 68
 - Default dataset, 69
 - Drive factory reset, 68
 - Parameter saving mode, 69
 - Save RAM to ROM, 69

Q

- Quick Startup, 33

R

- Reverse, 42

S

- Safety Parameters, 56
- saving, 56
- Screen icons
 - icons, 17
- Search by number, 55
- Sensor Control Field, 15
- Setpoint, 42
- Setting Reverse, 42
- Setting the Setpoint, 42
- Setting time and date, 24
- Startup in Hand, 46
- Status-screen wizard
 - Scalar value, 64
 - Trend view, 66

T

- Time and date settings, 70

U

- Up/Download, 56

W

- wizards, 30

Further information

SINAMICS converters:
www.siemens.com/sinamics

Safety Integrated:
www.siemens.com/safety-integrated

PROFINET:
www.siemens.com/profinet

Siemens AG
Digital Factory
Motion Control
Postfach 3180
91050 ERLANGEN
Germany

Subject to change without prior notice

For additional
information on
SINAMICS
IOP-2, scan the
QR code.

